

600W CENTARIO PRO | LED SPORT LIGHT



PRODUCT DESCRIPTION

THE CENTARIO PRO SERIES EVOLVES WITH AN ALL-NEW DESIGN! 5 YEAR WARRANTY! MORE EFFICIENT WITH HIGHER LUMENS, TOP-TIER UTEK DRIVERS, AND A NEW SIMPLE FLOOD MOUNT OPTION. THE CENTARIO PRO III IS UL CERTIFIED - THE PINNACLE OF SPORT LIGHTING!



#: RGL-CENTARIO-PRO-600W

PRODUCT FEATURES & COMMON USE APPLICATIONS

- ✓ UL cUL certificate
- ✓ Input voltage 120-277Vac
- ✓ No UV or IR in the beam
- ✓ Easy to install and operate
- ✓ Energy saving, long lifespan
- ✓ Instant start, NO flickering, NO humming
- ✓ Green and eco-friendly without mercury
- ✓ Output constant current lever can be adjusted through output cable with 0-10V.
- ✓ Stadium Fields
- ✓ Gymnasium
- ✓ Square plaza
- ✓ Shipyard, Airport, wharf
- ✓ High mast and Contour lighting, etc.

PRODUCT DIMENSIONS

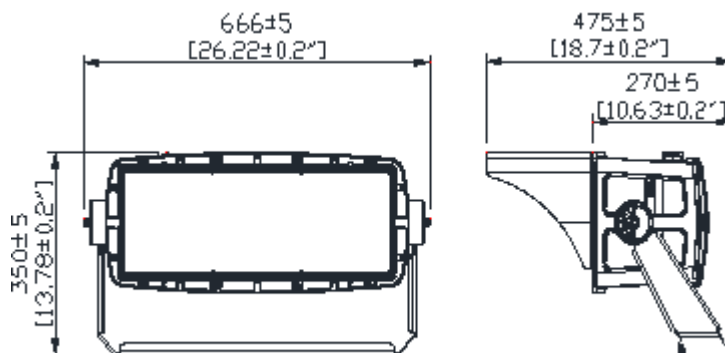

LEGENDARY USA SUPPORT



US based phone and online customer support

DLC CERTIFIED

5 YEAR WARRANTY



LISTED

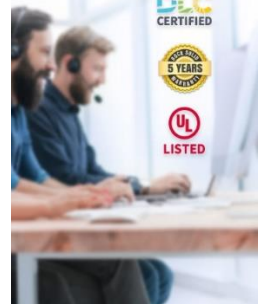

Rugged Grade Lighting
Industrial Grade Solutions



888-953-2476
sales@ruggedgrade.com



PRODUCT TECHNICAL SPECIFICATIONS

OPTICAL	Input Power (Tolerance: $\pm 10\%$)	600W
	Color Temperature	5000K
	Lumen (Tolerance: -10%)	87000 LM
	Efficacy (Tolerance: -3%)	145 LM/W
	CRI	>70
	Color Consistency	< 7 Steps (or < 7 SDCM)
	BUG	B5-U0-G5
	Distribution Pattern	NEMA:2
	Beam Angle (50%) (Tolerance: $\pm 15\%$)	35° (90° lens included in box)
ELECTRICAL	Input Voltage and Frequency	120-277VAC, 50/60Hz
	PF (Tolerance: -3%)	≥ 0.9
	THD (Tolerance: +5%)	$\leq 20\%$
	Flicker Percent	<5%
	Driver Brand	uPowerTek
	Driver Model	BLD-600-C420-ENU
	Driver Surge protection	L/N-PE: 10kV, L-N:6kV
	Dimming	0-10V dimming standard
	Optional Accessory	Sensor Receptacle + Photosensor / Sensor Receptacle + Short Cap / Surge-protective Device
MATERIALS	LED Brand	Bridgelux
	LED Type	SMD3030
	LED QTY	672 PCS
	Housing	Die-cast aluminum
	Housing Color	Black, Bronze, or Customized
	EPA	2.7 ft ²
	Waterproof Rating	WET (IP65)
OTHERS	Operating Temperature	-40°C TO 45°C
	Storage Temperature	-40°C TO 80°C
	Operating Humidity	20% - 90% RH
	Storage Humidity	10% - 95% RH
	Warranty	5 years warranty with 24/7 operating hours Luminaire lifetime at 25°C.

PRODUCT ACCESORIES



PRODUCT IMAGES & ACTUAL INSTALLATIONS



Actual Install - ECMX Motorsports Park MT

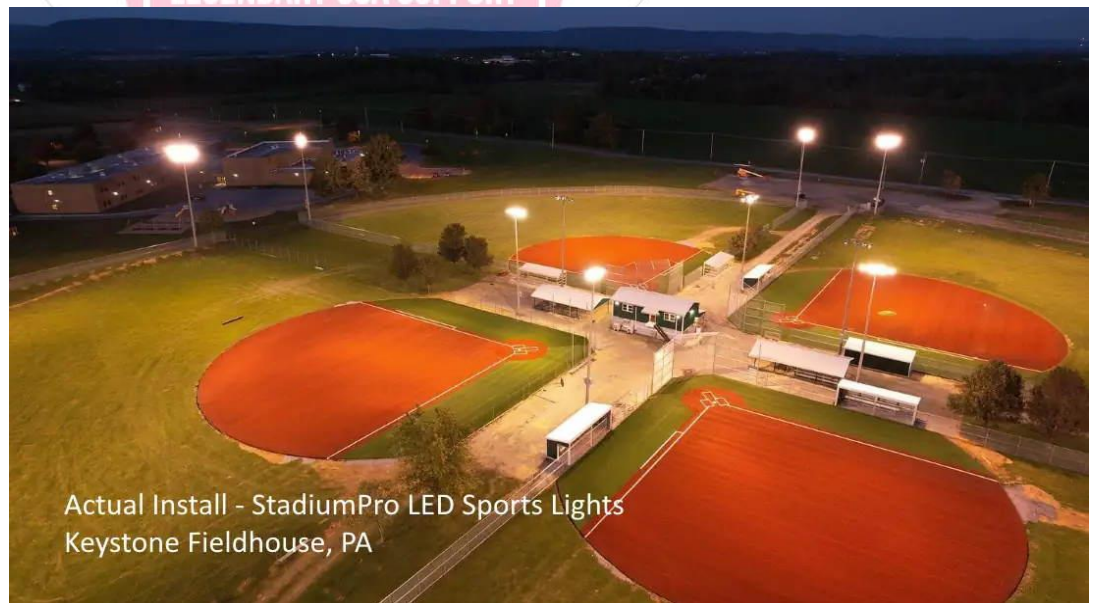

Actual Install - StadiumPro LED Sports Lights
Keystone Fieldhouse, PA



PHOTOMETRICS & DLC PRODUCT SPEC



PRODUCT PACKAGING

Stent Type	Lamps Net Weight	Size	Qty/ Carton	Weight/ Carton
Outer box	21Kg	700*380*310mm	1 PC	24.5Kg

Tolerance of Carton Size: ± 15 MM, Tolerance of Weight: $\pm 10\%$.



LEGENDARY USA SUPPORT



PRODUCT WARNINGS

- ⚡ Please turn off power before install or change assembly parts.
- ⚡ The input voltage and lamps should be matched, after connecting the power line.
- ⚡ Please make sure the wiring section is insulated.
- ⚡ Professionals must install and disassemble the lamps.
- ⚡ Surge is the number 1 cause of LED light failure. Outdoor lights must have surge at fixture, pole, and breaker.
- ⚡ Surge is the number 1 cause of LED light failure. Indoor lights must have surge at fixture and breaker.

PRODUCT TROUBLESHOOTING

Issue	Check points
Light Flickers	Check all wiring for disconnections, shorts and burnt wiring and connections. Confirm steady input voltage to the light fixture, fluctuating input voltage will harm the LED driver and can lead to premature failure. Lights with photocells can have photocell tag from ambient light or light reflecting at the sensor. Simply cover the photocell completely and see if flickering continues while the photocell is covered. Call Tech Support for help if none of the above solves the issue.
Light does not work at all.	Check all wiring for disconnections, shorts and burnt wiring and connections. Confirm steady input voltage to the light fixture, fluctuating input voltage will harm the LED driver and can lead to premature failure. If input voltage is not in the voltage range of the fixture, you will need to find the source of your input voltage issue. Call Tech Support for help if none of the above solves the issue.

For more technical information, install questions, troubleshooting help or warranty claims, we have a dedicated US Tech and Customer Support Team to help solve any issues you have and can be reached by email or phone. If you need help with any of our products, we are here for you so that you are never in the dark!

BETTER LIGHTS. BETTER SUPPORT.





CERTIFIED



LISTED





US based
phone and online
customer support



5 YEARS
WARRANTY