

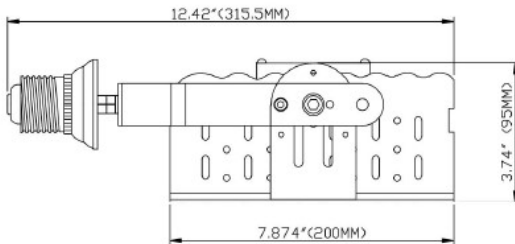

240 Watt LED Retrofit Kit - 30,200 Lumens - Ultra efficient LED 135 Lumen / Watt- Replacement Kit for High Bay, Parking Lot, Street, Wall Pack light. For any fixture. UL & DLC LED Retrofit Kit Light

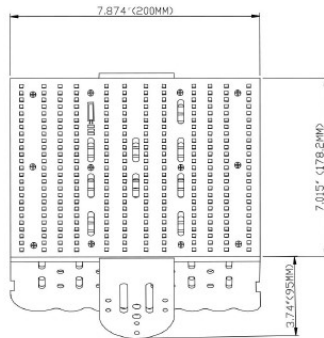

DIMENSIONS



LED RETROFIT KITS

- High Quality Lighting
- Easy Installation
- Safe and Environmentally Friendly
- Better Design Saving Energy

FEATURES

- 240W
- ETL cETL DLC approved
- Meanwell driver
- AC100-277V input
- Rotable Design
- SMD2835, SMD3030 LED chips
135-145Lm/W
- 120 degree beam angle
- Unique Cooling System designed with an aluminum fin heat sink Adjust 180 degree, E40 E39 socket
- High Lumens LED Chips
- 250Watt-1000Watt MH/HPS replacement
- 5 years warranty

APPLICATION

- Parking Lots, Tennis Courts Canopy
- Gas Stations
- Schools, Gardens
- Public Parks

Series	Lumens	Base	Beam Angle (Degree)	Electrical Data	LED Type	Color temperature	Color rendering index
NGRK-100W	14000LM 14,000 lumens	E39,E40	120 degree	Input Voltage 100-277V 50-60Hz Total Power(W) 100W 120W 150W 200W 240W Power Factor(%) >90	(100~150W) SMD2835 chips (200~240W) SMD3030 chips	WW 3000 K NW 4000 K DW 5000 K CW 5700 K	70 70 CRI 80 80 CRI 90 90 CRI
NGRK-120W	16800LM 16,800 lumens	E39,E40					
NGRK-150W	21000LM 21,000 lumens	E39,E40					
NGRK-200W	28000LM 28,000 lumens	E39,E40					
NGRK-240W	33600LM 33,600 lumens	E39,E40					

ROTABLE FUNCTION

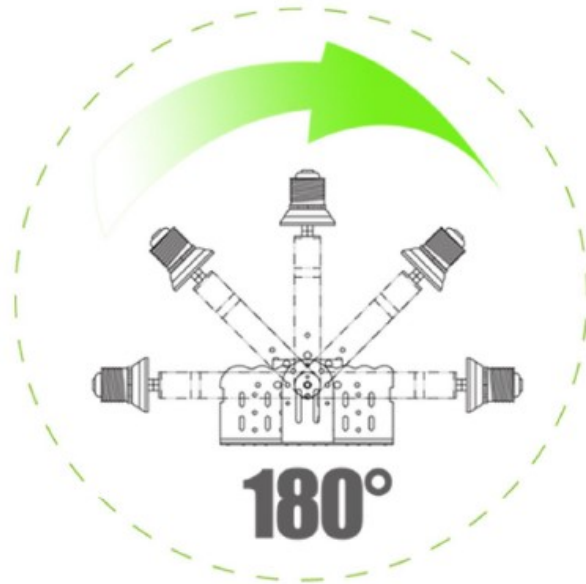

180°

Rotable 180°



360°

Rotable 360°

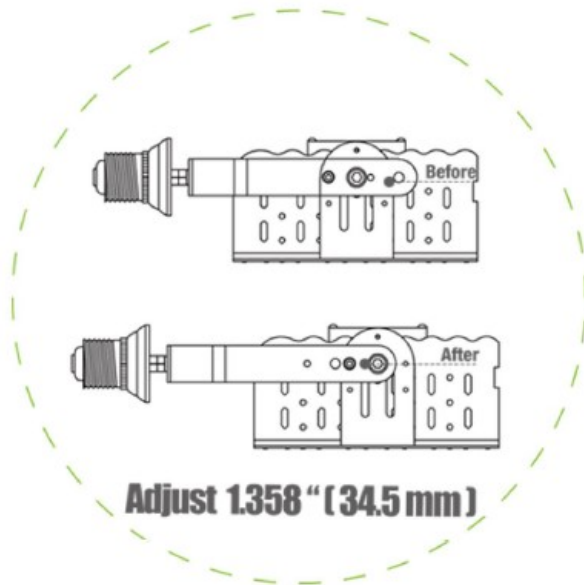

Adjust 1.358" (34.5 mm)

Adjust 1.358" (34.5 mm)

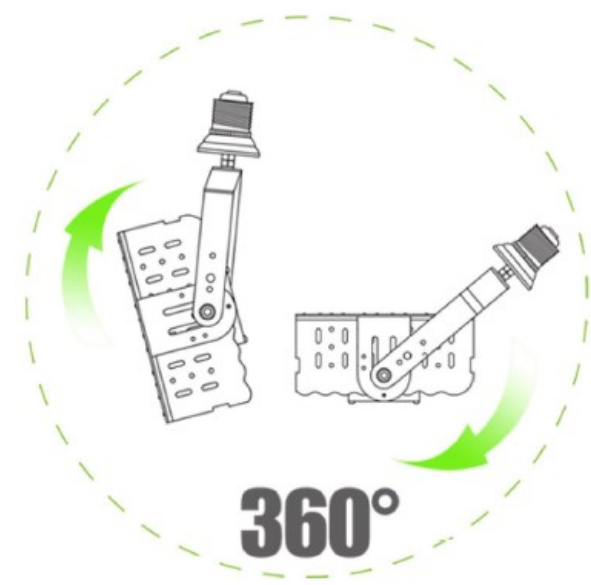

360°

Rotable 360°

IES REPORT

240W LED Retrofit Kits

Product Mark

Product Type :240W LED Retrofit Kits	Manufacturer :NO
Temperature :NO	Humidity :65%
Operator :admin	Test Date :2014-11-12 09:18:02
Remark:	

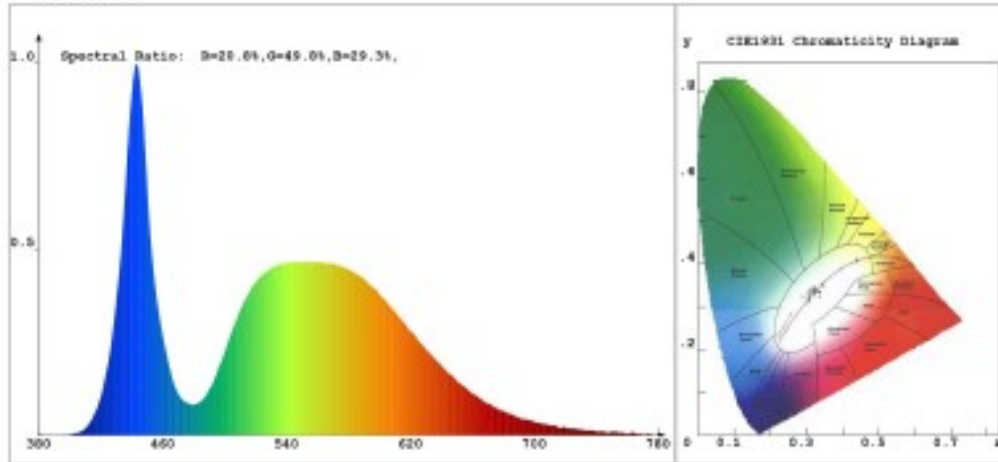

Chroma Parameters

Chro.Coor.:x=0.3198 y=0.3373 u=0.1996 v=0.3158 duv=0.0039
 CCT: 6096K Dominant Wave.:495.5nm Purity:4.3%
 Flux RGB Ratio:R=12.5%,G=85.2%,B=2.3% Peak Wave:443.5nm Half Width:19.4nm

Rendering Index:Ra= 71.2

R1 =70	R2 =73	R3 =76	R4 =73	R5 =72	R6 =67	R7 =78	R8 =60
R9 =0	R10=37	R11=74	R12=47	R13=69	R14=87	R15=64	

Photo Parameters

Flux:34058.28lm Effi.:138.9lm/W Radiant:53253.8mW RI:0.0mW/sr

Ele. Parameters

Voltage:U=220.300V	Current:I=0.7950A
Power:P=245.20W	Power Factor:PF=0.977

Instrument state

Instrument:Hopco HPS0005	Integral Time: 1.000ms	VPeak: 14672
VDark: 1245	Scan Range: 380-780nm	Product ID: 201308416

INSTALLATION INSTRUCTION

E39 E40 Retrofit kit with Meanwell driver:

1. E39 E40 base install in fixture socket
2. Output of Meanwell driver connect with fixture socket Red (DC+) connect Meanwell driver red line (L), Black (DC-) connect Meanwell driver black line(N)
3. Input of Meanwell driver connect 100-277VAC Green / Yellow (E) connect PE. Brown (AC+) connect L Blue (AC-) connect N
4. Turn on the light.

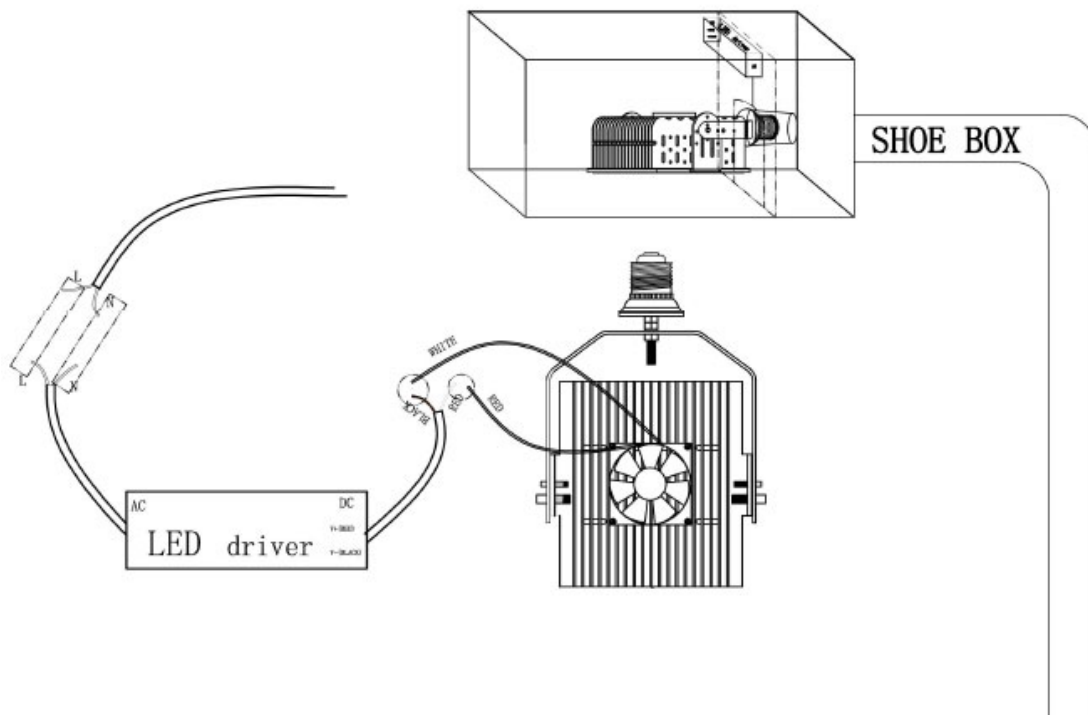

Caution: Please Remove Ballast, Capacitors and Ignitor.

PACKAGE

Power	Unit	Size	Gross weight	Volume
240W	1pcs	32.5*31 *15.5cm	3.378kg	0.015m ³
	4pcs	64*34*33cm	14.51kg	0.071m ³

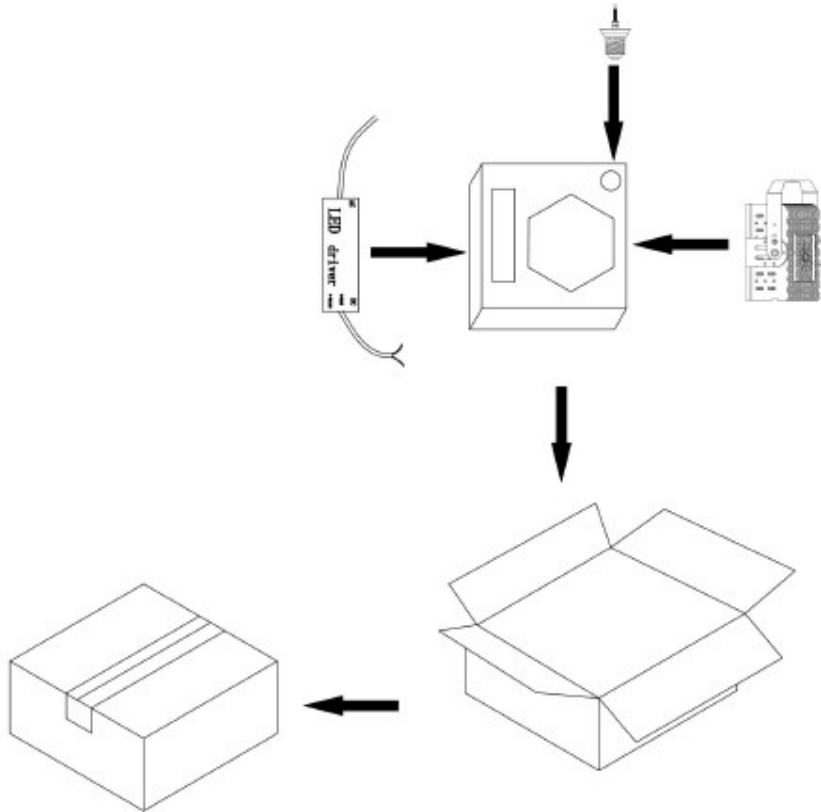

NOTICE FOR USER

- Please turn off power before install or change assembly parts.
- The input voltage and lamps should be matched, after connecting the power line, Please make sure the wiring section is insulated.
- Non-professionals, must not install and disassemble the lamps.

TROUBLESHOOTINGS

Issue	Check points
Light Flickers	Check all wiring for disconnections, shorts and burnt wiring and connections. Confirm steady input voltage to the light fixture, fluctuating input voltage will harm the LED driver and can lead to premature failure. Lights with photocells can have photocell tag from ambient light or light reflecting back at the sensor. Simply cover the photocell completely and see if flickering continues while the photocell is covered. Call Tech Support for help if none of the above solves the issue.
Light does not work at all.	Check all wiring for disconnections, shorts and burnt wiring and connections. Confirm steady input voltage to the light fixture, fluctuating input voltage will harm the LED driver and can lead to premature failure. If input voltage is not in the voltage range of the fixture, you will need to find the source of your input voltage issue. Call Tech Support for help if none of the above solves the issue.

For more technical information, install questions, troubleshooting help or warranty claims, we have a dedicated US Tech and Customer Support Team to help solve any issues you have and can be reached by email or phone. If you need help with any of our products, we are here for you so that you are never in the dark!



**BETTER LIGHTS.
BETTER SUPPORT.**

DLC CERTIFIED

UL LISTED

LEGENDARY RUGGEDGRADE QUALITY
LEGENDARY USA SUPPORT

US based phone and online customer support

ROCK SOLID 5 YEARS WARRANTY