



PRODUCT DESCRIPTION

Gorgeous Marcenti Series sets the tone for your entire business! Clean, Elegant and Powerful meets state of the art LED technology! Dark Sky Compliant and LED efficiency in a Modern Design.!



Part #: RGL-Marcenti-100W

PRODUCT FEATURES & COMMON USE APPLICATIONS

- ✓ Lumileds Chip, high CRI.
- ✓ Input voltage 120-277Vac
- ✓ No UV or IR in the beam
- ✓ Easy to install and operate
- ✓ Energy saving, long lifespan
- ✓ Instant start, NO flickering, NO humming
- ✓ Green and eco-friendly without mercury
- ✓ Output constant current lever can be adjusted through output cable with 0-10V.
- ✓ City Slow lane, Narrow Lane
- ✓ Residential Area, Plaza
- ✓ Building, The Hotel.
- ✓ Sightseeing Area, Village Road and so on

PRODUCT DIMENSIONS

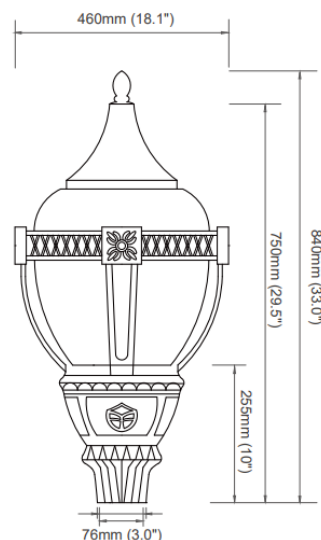

Rugged Grade Lighting
Industrial Grade Solutions



LEGENDARY USA SUPPORT



US based
phone and online
customer support

DLC
CERTIFIED

5 YEARS
WARRANTY

UL
LISTED



888-953-2476
sales@ruggedgrade.com



PRODUCT TECHNICAL SPECIFICATIONS

OPTICAL	Input Power (Tolerance: $\pm 10\%$)	60/80/100W(Wattage Adjustable)		
	Color Temperature	3000K	4000K	5000K
	Lumen (Tolerance: -10%)	10300 LM	11000 LM	10700 LM
	Efficacy (Tolerance: -3%)	103 LM/W	110 LM/W	107 LM/W
	CRI	>80		
	Color Consistency	< 7 Steps (or <7 SDCM)		
	Distribution Pattern	Type V		
	Beam Angle (50%) (Tolerance: $\pm 15\%$)	155*90 degree		
	Input Voltage and Frequency	120-277VAC, 50/60Hz		
ELECTRICAL	PF (Tolerance: -3%)	≥ 0.9		
	THD (Tolerance: +5%)	$\leq 20\%$		
	Flicker Percent	<30%		
	Driver Brand	RG		
	Driver Model	RG-150W-120v		
	Driver Surge protection	L/N-PE: 4kV, L-N 6kV		
	Dimming	0-10V dimming standard		
	Optional Accessory	Button Photocell Sensor Available		
	LED Brand	Lumileds		
MATERIALS	LED Type	SMD2835		
	LED QTY	143 PCS		
	Housing	Die-cast aluminum		
	Housing Color	Black,		
	Waterproof Rating	WET (IP65)		
	Operating Temperature	-40°C TO 50°C		
	Storage Temperature	-40°C TO 80°C		
OTHERS	Operating Humidity	5% - 95% RH		
	Storage Humidity	5% - 95% RH		
	Warranty	5 years warranty with 24/7 operating hours Luminaire lifetime at 25°C.		

PRODUCT ACCESORIES



PRODUCT IMAGES & ACTUAL INSTALLATIONS



PHOTOMETRICS

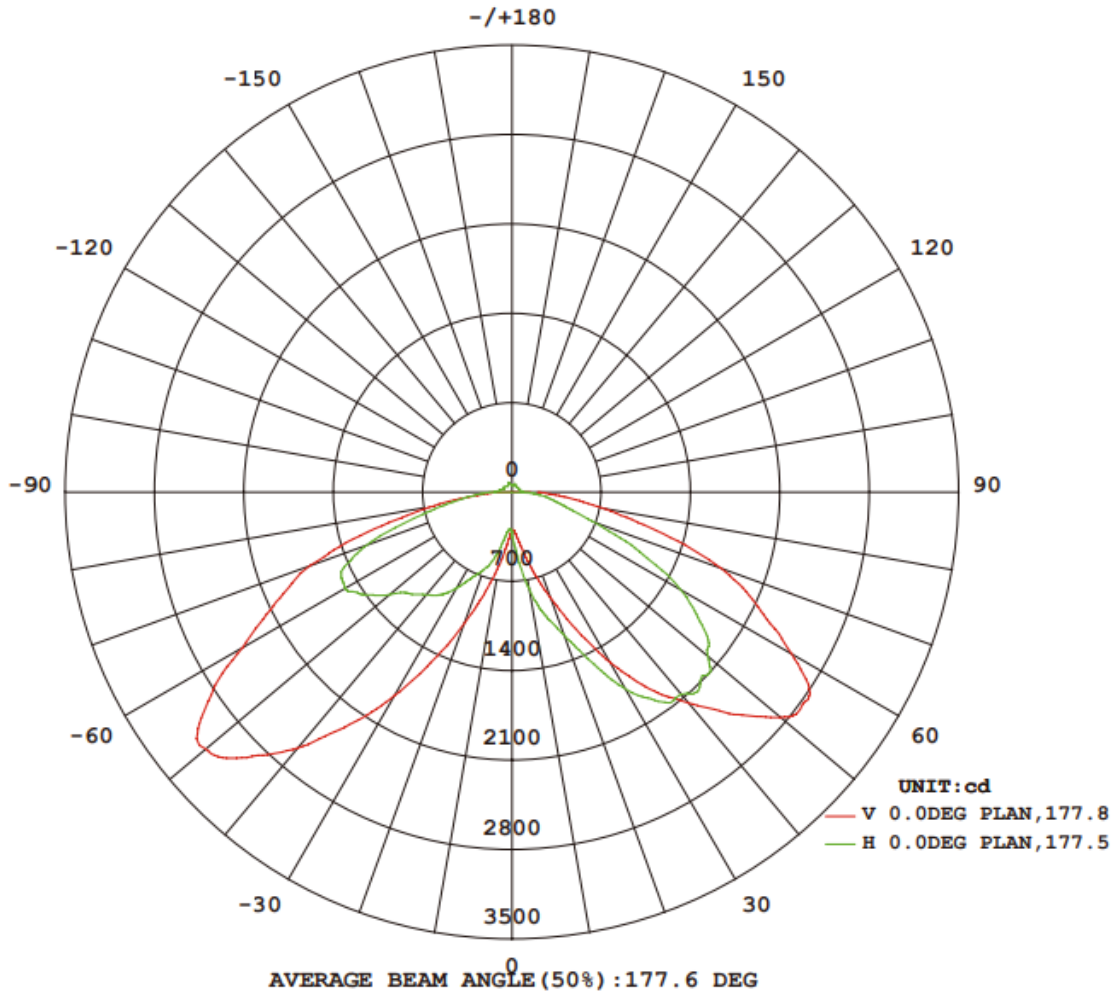

PRODUCT PACKAGING

Product Dimension (mm/in)	Carton Box Dimension (mm/in)	N.W (Kg/lb) (1pc)	G.W (Kg/lb) (1ctn)	qty/ctn
460 x 460 x 840 mm 18.10 x 18.10 x 33.00 in	540 x 540 x 680 mm 21.26 x 21.26 x 26.78 in	7Kg(15.5lbs)	10.2Kg(22.5lbs)	1 PCS

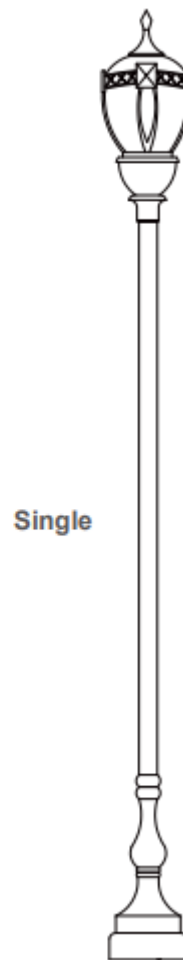
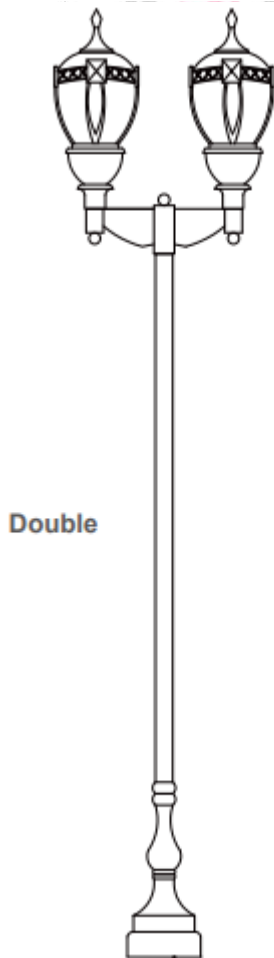
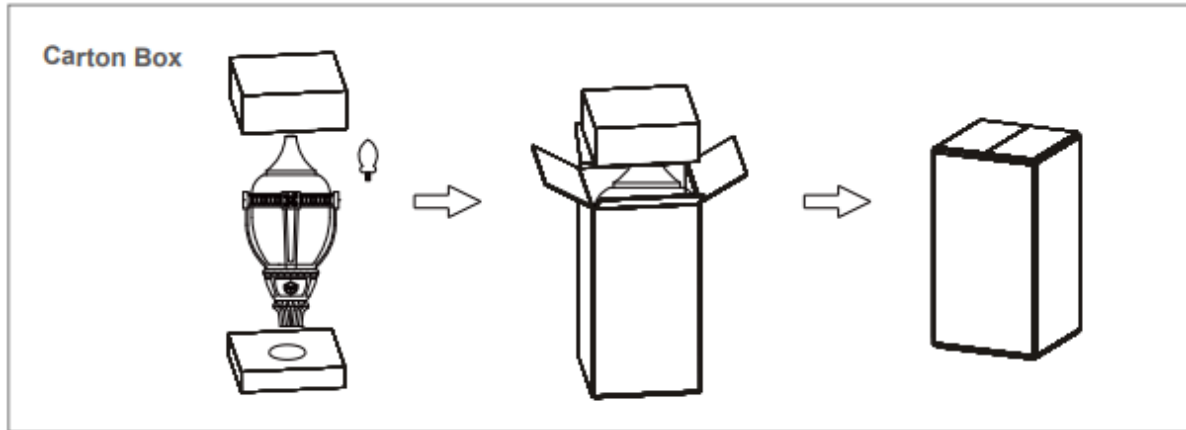

PRODUCT WARNINGS

- ⚡ Please turn off power before install or change assembly parts.
- ⚡ The input voltage and lamps should be matched, after connecting the power line.
- ⚡ Please make sure the wiring section is insulated.
- ⚡ Professionals must install and disassemble the lamps.
- ⚡ Surge is the number 1 cause of LED light failure. Outdoor lights must have surge at fixture, pole, and breaker.
- ⚡ Surge is the number 1 cause of LED light failure. Indoor lights must have surge at fixture and breaker.

PRODUCT TROUBLESHOOTING

Issue	Check points
Light Flickers	Check all wiring for disconnections, shorts and burnt wiring and connections. Confirm steady input voltage to the light fixture, fluctuating input voltage will harm the LED driver and can lead to premature failure. Lights with photocells can have photocell tag from ambient light or light reflecting at the sensor. Simply cover the photocell completely and see if flickering continues while the photocell is covered. Call Tech Support for help if none of the above solves the issue.
Light does not work at all.	Check all wiring for disconnections, shorts and burnt wiring and connections. Confirm steady input voltage to the light fixture, fluctuating input voltage will harm the LED driver and can lead to premature failure. If input voltage is not in the voltage range of the fixture, you will need to find the source of your input voltage issue. Call Tech Support for help if none of the above solves the issue.

For more technical information, install questions, troubleshooting help or warranty claims, we have a dedicated US Tech and Customer Support Team to help solve any issues you have and can be reached by email or phone. If you need help with any of our products, we are here for you so that you are never in the dark!

BETTER LIGHTS. BETTER SUPPORT.



CERTIFIED



LISTED





US based
phone and online
customer support



**5 YEARS
WARRANTY**