

PRODUCT DESCRIPTION

The Stellani LED Sconce Wall Light offers versatile lighting for outdoor spaces. Its Tunable Technology™ lets you adjust color temperature and brightness. With 0-10V dimming and a built-in dusk-to-dawn sensor, it's energy-efficient and automatically adjusts. The light's durable design includes 6kV surge protection, aluminum housing, and a 60° glass diffuser. Easy installation, backed by a 5-year warranty, makes it a reliable choice for customizable illumination.



DLC #:

PRODUCT FEATURES & COMMON USE APPLICATIONS

- UL cUL certificate.
- Lumileds 2835, high CRI.
- Input voltage 120-277VAC.
- Output constant current lever can be adjusted through output cable with 0-10V.
- Wattage adjustable
- No UV or IR in the beam.
- Easy to install and operate.
- Energy saving, long lifespan.
- Light is soft and uniform, safe to eyes.
- Instant start, NO flickering, NO humming.
- Green and eco-friendly without mercury
- Entrance lighting, courtyard lighting;
- Industrial lighting, Outdoor landscape lighting;
- Building, The hotel;
- Wall lighting area and so on.

PRODUCT DIMENSIONS

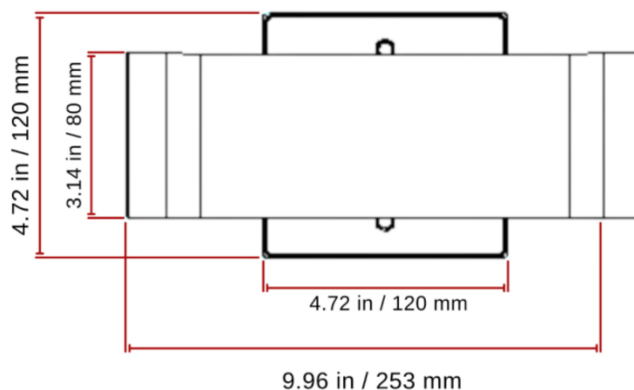
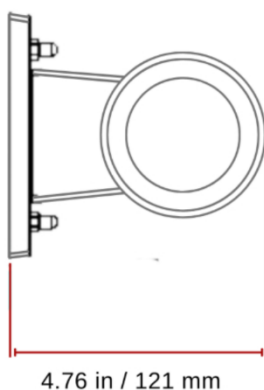

LEGENDARY USA SUPPORT



US based phone and online customer support

DLC CERTIFIED

5 YEARS WARRANTY





PRODUCT TECHNICAL SPECIFICATIONS

OPTICAL	Input Power (Tolerance : ±10%)	30W		
	Color Temperature(Color tunable)	3000K	4000K	5000K
	Lumen (Tolerance : -10%)	3300LM/W	3600LM	3540LM
	Efficacy (Tolerance : -3%)	110LM/W	120LM/W	118LM/W
	CRI	>80		
	Color Consistency	< 8 Steps (or <8 SDCM)		
	BUG	B2-U2-G2		
	Diffuser Type	Glass		
	Beam Angle (50%) (Tolerance : ±15%)	60 Degree		
ELECTRICAL	Input Voltage and Frequency	120-277VAC 50/60Hz		
	PF (Tolerance : -3%)	≥0.9		
	THD (Tolerance : +5%)	≤20%		
	Flicker Percent	<30%		
	Driver Brand	RuggedGrade Lighting		
	Driver Model	RuggedGrade Lighting Driver		
	Driver Surge protection	L-N: 6kV , L&N-PE:6kV		
	Dimming	0-10V dimming standard		
	Sensor Type	No Sensor		
	Optional Accessory	NA		
MATERIALS	LED Brand	LUMILEDS		
	LED Type	SMD 2835		
	LED QTY	48*2 PCS		
	Housing	Die-cast aluminum		
	Housing Color	All Color		
	Waterproof Rating	WET (IP65)		
OTHERS	Operating Temperature	-40°C TO 50°C		
	Storage Temperature	-40°C TO 80°C		
	Operating Humidity	20% - 90% RH		
	Storage Humidity	10% - 95% RH		
	Warranty	5 years warranty		

PRODUCT MOUNTS & ACCESSORIES



PRODUCT IMAGES & ACTUAL INSTALLATIONS



PRODUCT WARNINGS

- ⚡ Please turn off power before install or change assembly parts.
- ⚡ The input voltage and lamps should be matched, after connecting the power line.
- ⚡ Please make sure the wiring section is insulated.
- ⚡ Professionals must install and disassemble the lamps.
- ⚡ Surge is the number 1 cause of LED light failure. Outdoor lights must have surge at fixture, pole, and breaker.
- ⚡ Surge is the number 1 cause of LED light failure. Indoor lights must have surge at fixture and breaker.

PRODUCT TROUBLESHOOTING

Issue	Check points
Light Flickers	Check all wiring for disconnections, shorts and burnt wiring and connections. Confirm steady input voltage to the light fixture, fluctuating input voltage will harm the LED driver and can lead to premature failure. Lights with photocells can have photocell tag from ambient light or light reflecting at the sensor. Simply cover the photocell completely and see if flickering continues while the photocell is covered. Call Tech Support for help if none of the above solves the issue.
Light does not work at all.	Check all wiring for disconnections, shorts and burnt wiring and connections. Confirm steady input voltage to the light fixture, fluctuating input voltage will harm the LED driver and can lead to premature failure. If input voltage is not in the voltage range of the fixture, you will need to find the source of your input voltage issue. Call Tech Support for help if none of the above solves the issue.

For more technical information, install questions, troubleshooting help or warranty claims, we have a dedicated US Tech and Customer Support Team to help solve any issues you have and can be reached by email or phone. If you need help with any of our products, we are here for you so that you are never in the dark!

**BETTER LIGHTS.
BETTER SUPPORT.**

