



SPECIFICATIONS and FEATURES

 **HIGH VOLTAGE OUTPUT**
170VDC

 **CONSTANT POWER**
EMERGENCY OUTPUT

Self Test



Input Voltage	Input Current	Input Power Rating	Time Recharge	Output Voltage	Emergency Power	Discharge Time	Vaux	Ambient Temp
120-347V/AC	200mA max	12W max	24H	170Vdc	18W	1.5H	12V/DC 0.17A	0~50°C

LUMEN OUTPUT DURING EMERGENCY OPERATION

The luminaire rated data and maximum mounting height can be found as follows:

- Determine the fixture efficacy under normal AC operation, based on fixture manufacturer published data in lumens per watt (LM/W)
- Reference DLC QPL (www.designlights.org) and Energy Star QPL (www.energystar.gov) for rated data on fixture efficacy. If fixture is not found on DLC or Energy Star Qualified Product List, contact fixture manufacturer.
- Multiply fixture LMW by rated output power of emergency pack Example 'model EM-45170D'. FY is 15 w x 100 LMW = 1500 Lumens

- J BOX Outdoor Design, UL Listed for US and CANADA
- Listed to UL924 and tested to CSA C22.2NO.141 Field or factory installation
- Low energy consumption CE Title 20 compliance
- Constant output power
- Self-testing
- Battery with over temperature protection
- Built-in Integrated junction box
- For wiring to the led driver's input



DIMENSIONS

SIZE: L7.95"(202mm), *W4.96"(126.2mm)W3.28"(83.5mm)

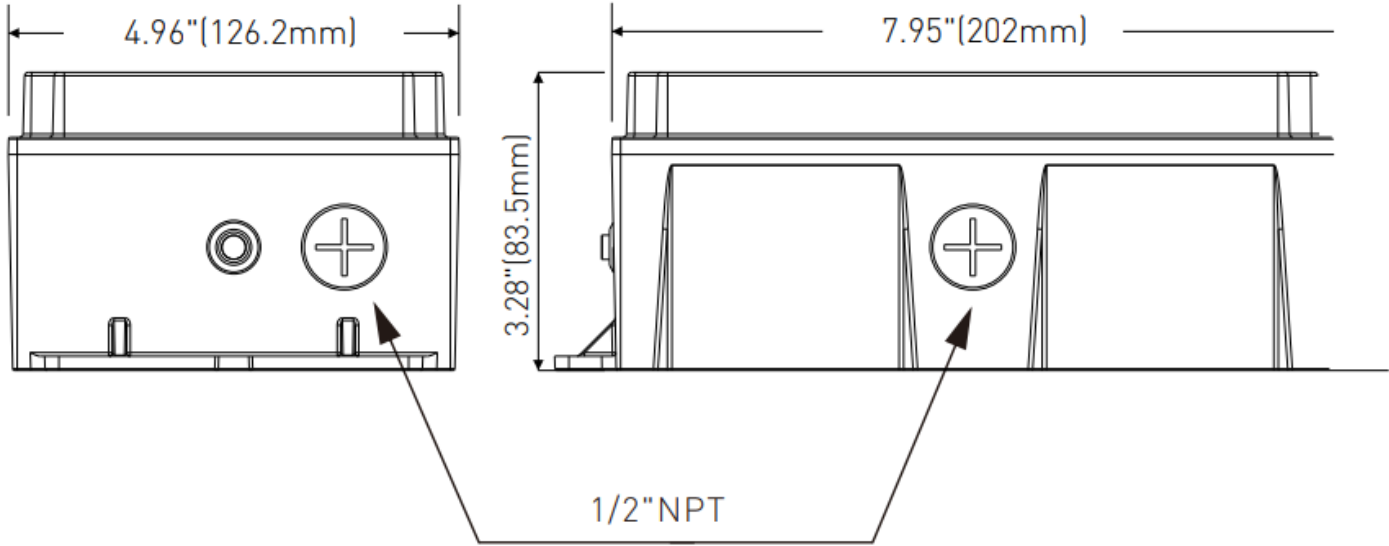

1/2" NPT

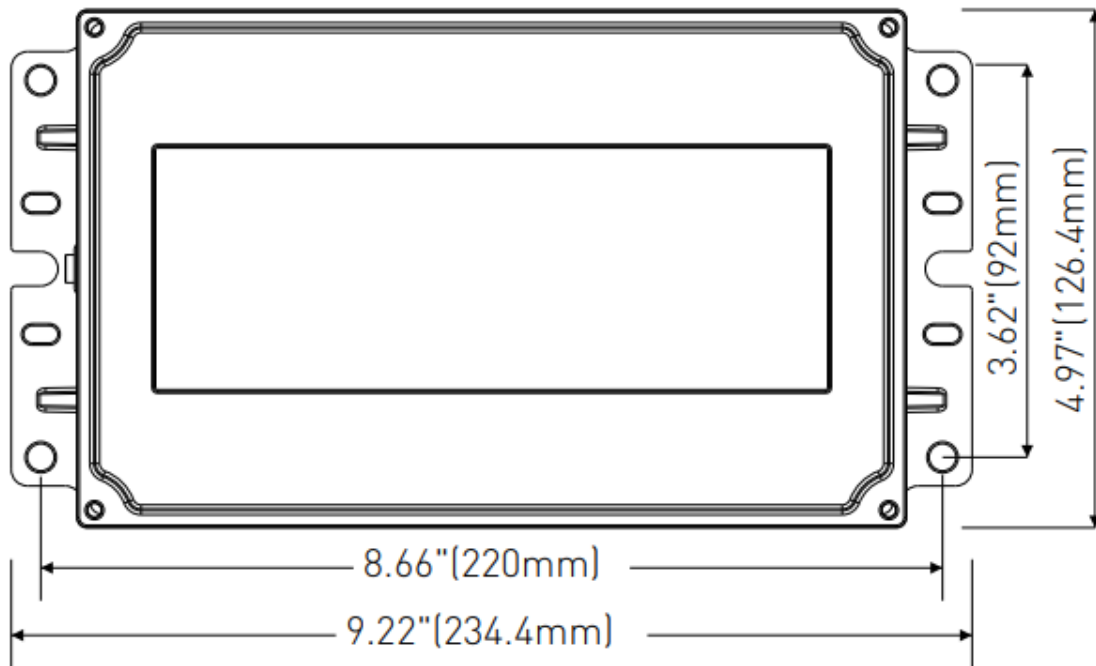



INSTALLATION GUIDE

▶ READ AND FOLLOW ALL SAFETY INSTRUCTION

- CAUTION- This EMJ provides more than one power supply output source. To reduce the risk of electrical shock, disconnect both normal and emergency source by turning off the A.C. branch circuit.
- CAUTION- Servicing of this equipment should be performed by qualified personnel only.
- CAUTION- Do not attempt to service the battery. A sealed, no-maintenance battery is used that is not field replaceable. Replace the entire unit when necessary.
- The use of accessory equipment not recommended by the manufacturer may cause an unsafe condition, void warranty, and result in non-compliance with UL specifications.
- CAUTION- The EMJ requires an un-switched AC power source of 100-347VAC, 50/60Hz. Installer must confirm that fixture input voltage covered 120VAC before installation. It will supply power under an output voltage of 170VDC in emergency mode for at least 90 minutes.
- CAUTION- Battery pack should be charged for 24 hours every 6 months during storage.
- Battery in this unit may not be fully charged. After electricity is connected to the unit for at least 24 hours, then normal operation of this unit should take effect.
- For use in 0°C minimum, 50°C maximum ambient temperatures. Suitable for use in damp locations and plenum spaces.
- Flexible metal conduit is optional, depend on installation environment.
- The EMJ should be mounted in locations and at heights where it will not readily be subjected to tampering by unauthorized personnel.
- Do not use this equipment for anything other than its intended use. Equipment only use for LED Lighting emergency backup.
- Do not mount near gas or electric heaters. Do not let power supply cords touch hot surfaces.
- Do not mount near gas or electric heaters. Do not make or leave any other open holes in the wiring enclosure or electrical component enclosure during installation.
- This fixture is for use with grounded, UL Listed, damp location rated, indoor fixture. Not for use in heated air outlets or hazardous locations.
- Do not use outdoor.

▶ SELF-DIAGNOSTIC (MAINTENANCE)

- The integrated Self-Diagnostic circuitry will automatically conduct 1 monthly 30-second and annual 90-minute tests to verify proper emergency capability per Life Safety Code requirements. NFPA 101, Life Safety Code Outlines the following schedule:
- **Monthly**- During AC mode, the system conducts a (30)seconds self-discharge test of the emergency led driver every 30 days. And automatically restore to normal charging after (30)seconds dis-charged.
- **Annually**- During AC mode, the system conducts a (90)minutes self-discharge test of the emergency led driver every 365 days. And automatically restore to normal charging after fully dis-charged.
- **"Written Records of the Testing should be kept by the owner for inspection by the authority having jurisdiction."** If the charging indicator is flashing rapidly or off, contact manufacturer.

▶ Installation instructions

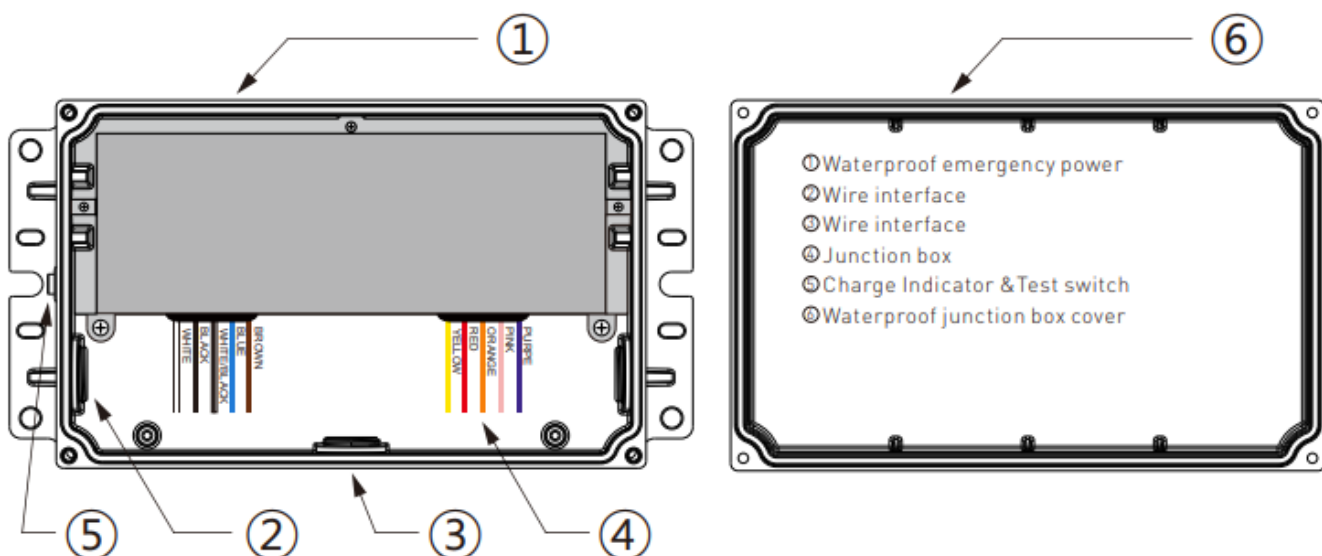

WIRING GUIDE

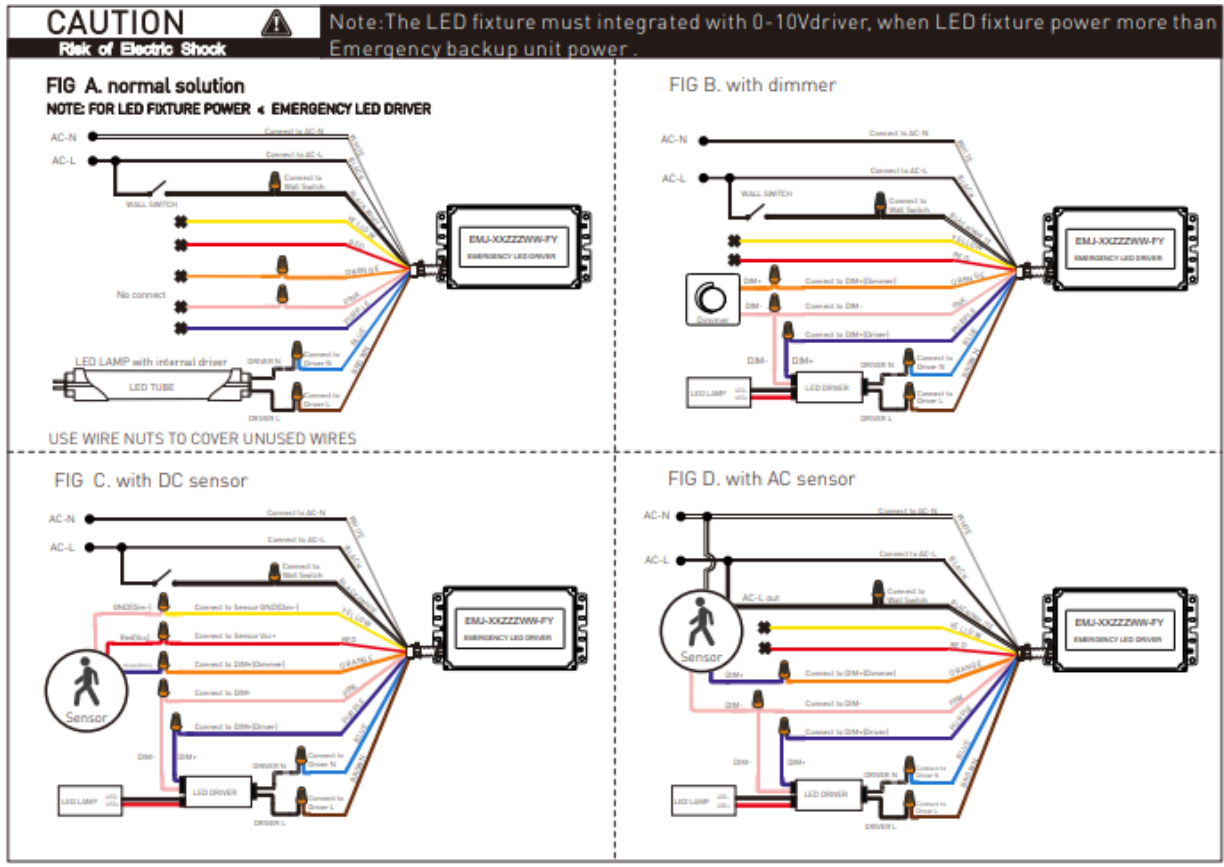

Caution: Before Installation, Make Certain The A.C. Power is Off !

STEP1: INSTALLING THE EMERGENCY LED DRIVER

- Turn off the AC power before installing.
- Indicator light and test switch should be mounted where can be seen by the maintenance personnel.
- The voltage input to the dimmable wires (DIM+, DIM-) of emergency LED driver must less than 20Vdc.
- Determine appropriate location for EMJ in the fixture or using existing mounting holes in the fixture. The installation instruction of LED luminaire may provide guidance on mounting location.

STEP 2: WIRING THE EMERGENCY DRIVER

- Open the cover of junction box.
- Select the appropriate wiring diagram to connect the emergency driver to the AC diver. For other diagrams, consult the manufacturer.
- Using wire nuts to cover unused wires and make sure all connections are in accordance with the NEC and any local regulations.

STEP3: TESTING

- After wiring is complete, check if the indicator light lights or not, which will indicate the battery's charging situation.
- The battery in this unit may not be fully charged. A short-term discharge test may be conducted after the EMJ has been charging for 1 hour. Charge for 24 hours before conducting a long-term discharge test.



OPERATIONAL GUIDE

Mode	Test Switch Operation	Indicator Status	Comment & Solutions
AC MODE (1)	NO Pressed	ON(no flashing)	Emergency Driver is charging
AC MODE (2)	Pressed once	2s ON and 2s OFF [slow flashing]	Emergency Driver is conducting a 30s short-term emergency test
AC MODE (3)	Pressed twice [2s] in sequence	2s ON and 2s OFF [slow flashing]	Emergency Driver is conducting a long-term emergency test until battery is fully discharged
EMERGENCY MODE (1)	NO Pressed	2s ON and 2s OFF [slow flashing]	Emergency Driver is automatically conducting a emergency until battery is fully discharged
EMERGENCY MODE (2)	Pressed once	OFF	Emergency Driver is turned off
PROBLEM	When indicator flashes (0.2s) ON and (0.2s)OFF fast or goes off, the emergency backup pack is abnormal. Contact the manufacturer.		

WARNING
Risk of Electric Shock



Note:..Please pressed test switch of the EMJ(in once) and make certain the battery is turned off, before installation, maintenance, storage or shipping.



PRODUCT PACKAGING

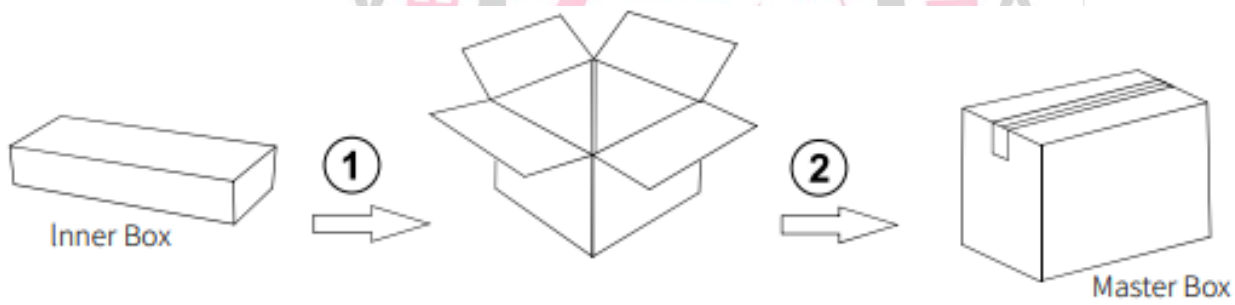

Power	Length(inch)	Width(inch)	Height(inch)	G.W(kg)	N.W(kg)	QTY(pcs)
18W	18.5"	9.92"	11.01"	14.6	12.6	10

