

PRODUCT DESCRIPTION

New Fully Tunable Panel allows you to perfectly customize your settings to fit your needs. 3CCT switch makes it easy to switch between 3000k, 3500k, 4000k, 5000k and 6000K also the wattage selectable switch allows you to dim the light as needed.



#: RGL-PANEL-72W

PRODUCT FEATURES & COMMON USE APPLICATIONS

- UL Cul, DLC certificate.
- Lumileds or Samsung Chip, high CRI.
- Input voltage 120-277VAC.
- Output constant current lever can be adjusted through output cable with 0-10V.
- No UV or IR in the beam.
- Easy to install and operate.
- Energy saving, long lifespan.
- Light is soft and uniform, safe to eyes.
- Instant start, NO flickering, NO humming.
- Green and eco-friendly without mercury.
- Warehouse, factory, and workshops.
- Highway toll station and gas station.
- Exhibition hall.
- Schools
- Offices
- Gymnasium and supermarkets, etc

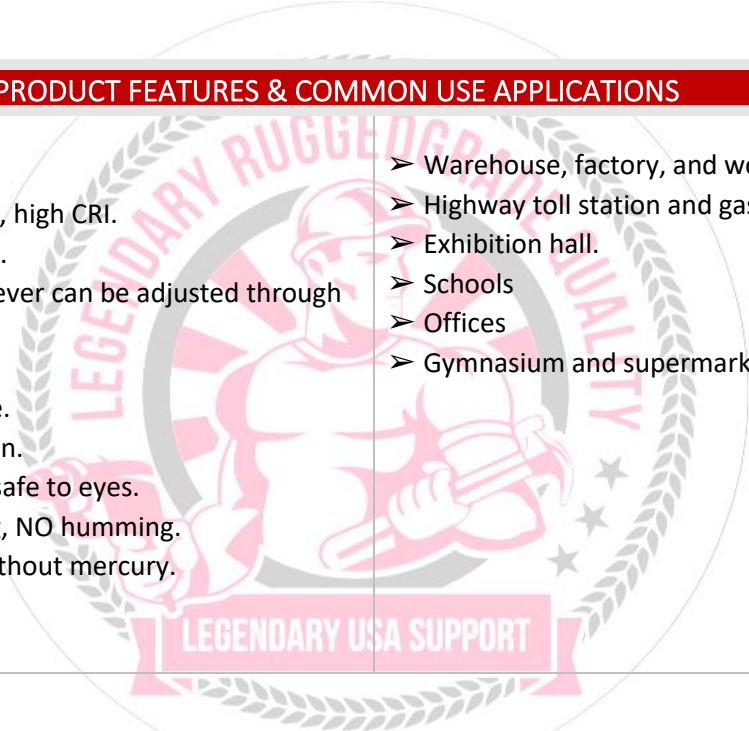

PRODUCT DIMENSIONS

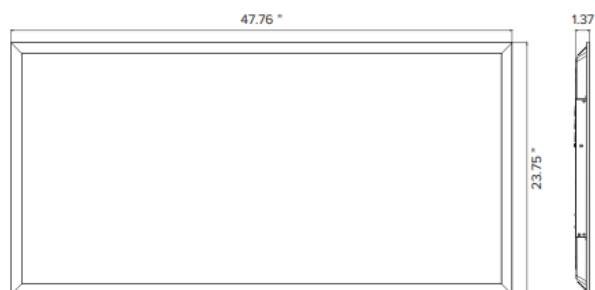
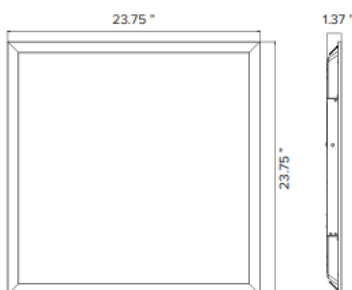

LEGENDARY USA SUPPORT





PRODUCT TECHNICAL SPECIFICATIONS

OPTICAL	Input Power (Tolerance : ±10%)	72W(Wattage Selectable 30/40/50/60/72W)				
	Color Temperature	3000K	3500K	4000K	5000K	6500K
	Lumen (Tolerance : -10%)	8000LM	8100LM	8200LM	8500LM	9000LM
	Efficacy (Tolerance : -3%)	111LM/W	113LM/W	115LM/W	118LM/W	125LM/W
	CRI	>80				
	Color Consistency	< 6 Steps (or < 6 SDCM)				
	UGR (Glare Rating)	< 28				
	Diffuser Type	PC Lens				
ELECTRICAL	Beam Angle (50%) (Tolerance :	110 Degree				
	Input Voltage and Frequency	120-277VAC, 50/60Hz (120-347vac optional)				
	PF (Tolerance : -3%)	≥0.9				
	THD (Tolerance : +5%)	≤15%				
	Flicker Percent	< 5%				
	Driver Brand	Rugged Grade Lighting				
	Driver Model	Rugged Grade Lighting Driver				
	Driver Surge protection	L/N-PE: 6kV, L-N: 4kV				
MATERIALS	Dimming	0-10V dimming standard				
	Optional Accessory	Motion Sensor, Surge-protective Device				
	LED Brand	Lumileds				
	LED Type	SMD2835				
	LED QTY	96PCS				
	Housing	Die-cast aluminum				
	Housing Color	White				
OTHERS	Waterproof Rating	Damp (IP41)				
	Operating Temperature	-4°F to 104°F(-20°C to 40°C)				
	Storage Temperature	-40°C TO 45°C				
	Operating Humidity	20% - 90% RH				
Storage Humidity	10% - 95% RH					
Warranty	5 years warranty with 24/7 operating hours Luminaire lifetime					

PRODUCT MOUNTS & ACCESSORIES



Suspension mounting kits



Emergency Battery Backup



Sensor



Surface mount kit



PRODUCT IMAGES & ACTUAL INSTALLATIONS



5-in-1 Color Temperature
(3000K 3500K 4000K 5000K 6500K)
5-in-1 Wattage (30 40 50 60 72W)
Hassle-Free Set up
0-10V Dimming, Triac dimming
Support Emergency, Sensor, Bluetooth

5 Wattage and 5 CCT
selectable switches



Cable Mount Kit

Optional Y cable mounting kit allows for suspended installations from any ceiling type. (2 pcs/kit)

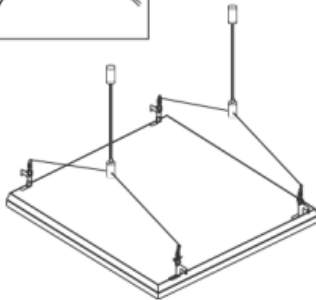
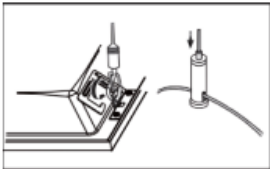

Surface Mount Kit

Optional surface mount kit allows for installation on plaster or other hard ceilings.

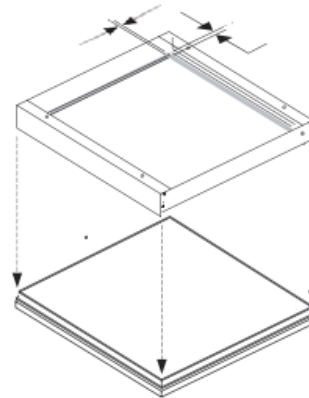

INSTALLATION & WIRING DIAGRAM

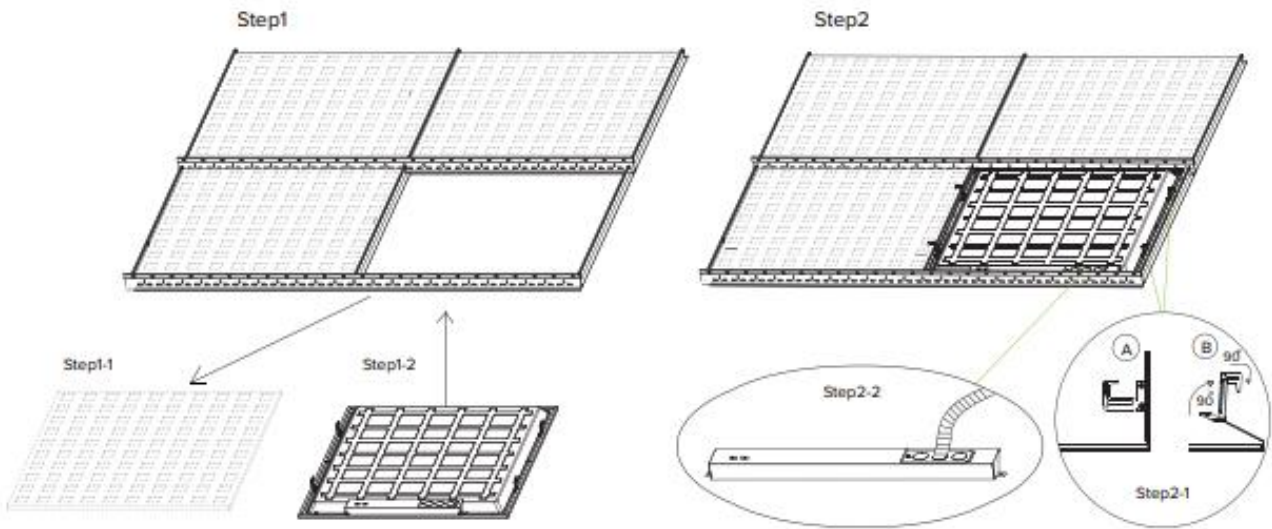
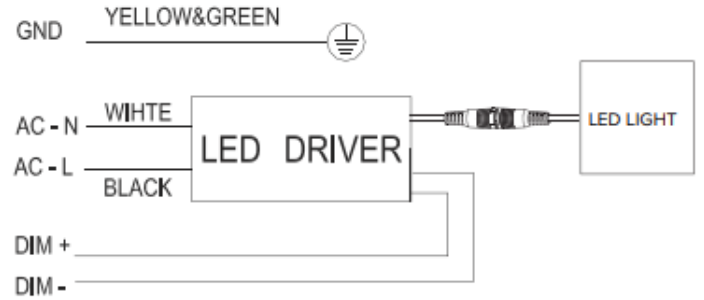
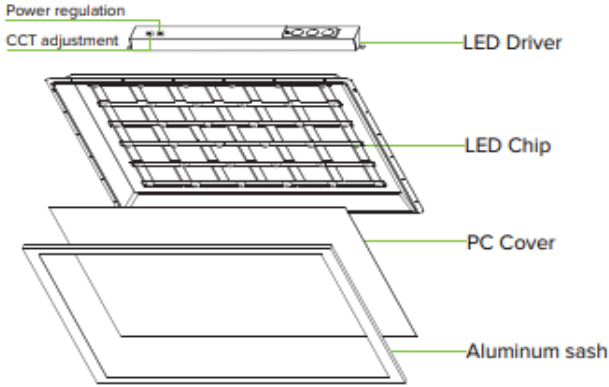

PRODUCT PACKAGING

Size/ft	L /inch	W /inch	H /inch	QTY/ctn	G.W./lbs	CTN QTY/pallet
2x2'	25.2	25.2	6.5	4	16.23	144pcs
2x4'	49.2	25.2	6.5	4	39.30	72pcs

*Tolerance of Carton Size: ± 15 MM, Tolerance of Weight: $\pm 10\%$.

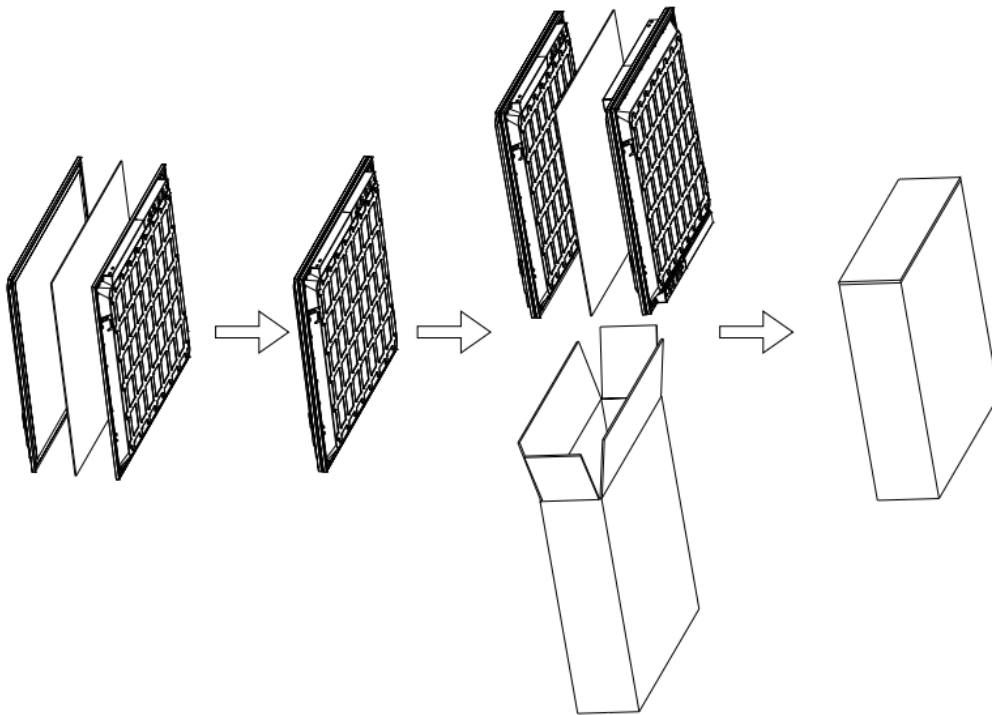

PRODUCT WARNINGS

- ⚡ Please turn off power before install or change assembly parts.
- ⚡ The input voltage and lamps should be matched, after connecting the power line.
- ⚡ Please make sure the wiring section is insulated.
- ⚡ Professionals must install and disassemble the lamps.
- ⚡ Surge is the number 1 cause of LED light failure. Outdoor lights must have surge at fixture, pole, and breaker.
- ⚡ Surge is the number 1 cause of LED light failure. Indoor lights must have surge at fixture and breaker.

PRODUCT TROUBLESHOOTING

Issue	Check points
Light Flickers	Check all wiring for disconnections, shorts and burnt wiring and connections. Confirm steady input voltage to the light fixture, fluctuating input voltage will harm the LED driver and can lead to premature failure. Lights with photocells can have photocell tag from ambient light or light reflecting at the sensor. Simply cover the photocell completely and see if flickering continues while the photocell is covered. Call Tech Support for help if none of the above solves the issue.
Light does not work at all.	Check all wiring for disconnections, shorts and burnt wiring and connections. Confirm steady input voltage to the light fixture, fluctuating input voltage will harm the LED driver and can lead to premature failure. If input voltage is not in the voltage range of the fixture, you will need to find the source of your input voltage issue. Call Tech Support for help if none of the above solves the issue.

For more technical information, install questions, troubleshooting help or warranty claims, we have a dedicated US Tech and Customer Support Team to help solve any issues you have and can be reached by email or phone. If you need help with any of our products, we are here for you so that you are never in the dark!

**BETTER LIGHTS.
BETTER SUPPORT.**

