

# 90W | FULLY TUNABLE LED 8FT STRIP LIGHT



## PRODUCT DESCRIPTION

This 90-watt fully tunable 8ft LED linear strip light delivers powerful illumination with customizable color temperatures and dimming options. Ideal for commercial, retail, and industrial spaces, this fixture outputs up to 11,700 lumens and replaces outdated T8 or T5HO setups with ease. Its color-selectable design (4000K, 5000K, 5700K, or 6500K) and 0–10V dimming



#: RGL-8FT-VAP-90W-TT

## PRODUCT FEATURES & COMMON USE APPLICATIONS

- UL cUL DLC certificate.
- Lumileds or Samsung Chip, high CRI.
- Input voltage 120-277VAC.
- No UV or IR in the beam.
- Easy to install and operate.
- Energy saving, long lifespan.
- Light is soft and uniform, safe to eyes.
- Instant start, NO flickering, NO humming.
- Green and eco-friendly without mercury.
- Warehouse, factory, and workshops.
- Highway toll station and gas station.
- Exhibition hall.
- Gymnasium and supermarkets, etc

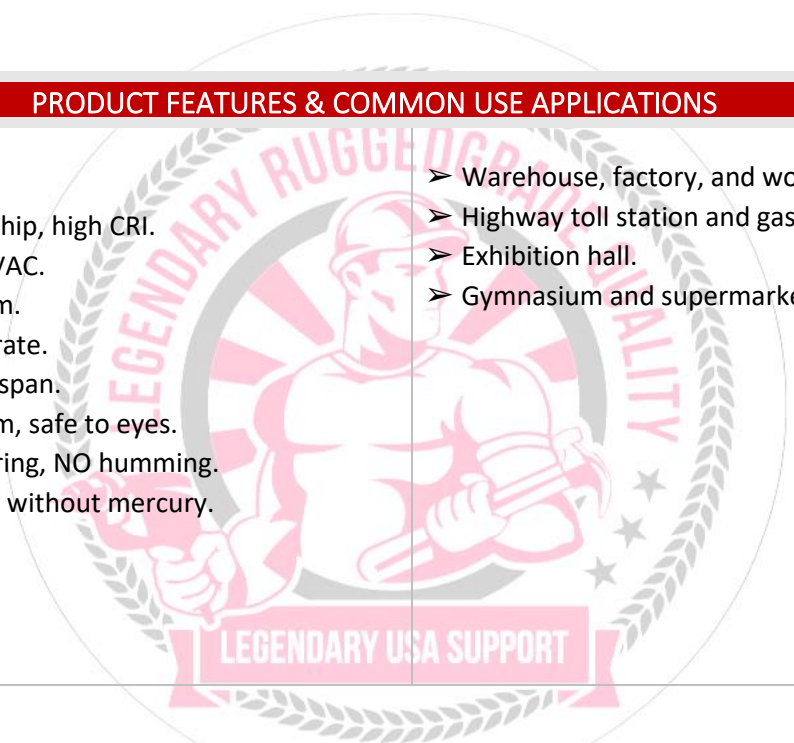

## PRODUCT DIMENSIONS

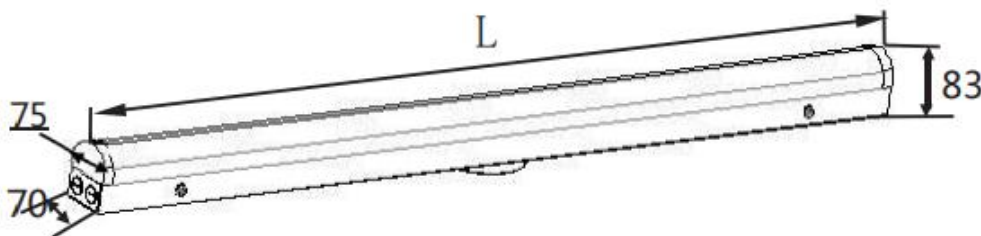

Length	Width	Height
48"	2.95"	3.27"
96"	2.95"	3.27"

Rugged Grade Lighting  
Industrial Grade Solutions



888-953-2476  
sales@ruggedgrade.com

## LEGENDARY USA SUPPORT



US based phone and online customer support



## PRODUCT TECHNICAL SPECIFICATIONS

<b>OPTICAL</b>	Input Power (Tolerance : ±10%)	70/80/90W(Wattage Selectable)
	Color Temperature	3500K-6500K(Color Selectable)
	Lumen (Tolerance : -10%)	11700 LM
	Efficacy (Tolerance : -3%)	130 LM/W
	CRI	>80
	Color Consistency	<7 Steps (or <7 SDCM)
	UGR (Glare Rating)	<28 (X=4H, Y=8H; S/H=1; Reflectances: 70%/50%/20%)
	Diffuser Type	PC Lens
<b>ELECTRICAL</b>	Beam Angle (50%) (Tolerance :	110 Degree
	Input Voltage and Frequency	120-277VAC, 50/60Hz
	PF (Tolerance : -3%)	≥0.95
	THD (Tolerance : +5%)	≤10%
	Driver Efficacy	<90%
	Driver Brand	Rugged Grade Lighting
	Driver Model	Rugged Grade Lighting Driver
	Driver Surge protection	L/N-PE: 6kV, L-N: 4kV
	Dimming	Wattage Selectable Switch
Optional Accessory	15W Battery Back up	
<b>MATERIALS</b>	LED Brand	Lumileds
	LED Type	SMD2835
	LED QTY	198PCS
	Housing	PC
	Housing Color	Grey
	Waterproof Rating	WET (IP65)
<b>OTHERS</b>	Operating Temperature	-40F TO 104F
	Storage Temperature	-40F TO 104F
	Operating Humidity	20% - 90% RH
	Storage Humidity	10% - 95% RH
	Warranty	5 years warranty with 24/7 operating hours Luminaire lifetime at

## PRODUCT MOUNTS & ACCESSORIES



Sensor: ANT-5-4T



Emergency Battery



Wire Rope



Ceiling accessories



Connecting Piece





### PRODUCT IMAGES & FEATURES



5-in-1 Color Temperature  
(3500K 4000K 5000K 5700K 6500K)  
3-in-1 Wattage (70 80 90W)  
0-10V Dimming  
Linkable  
Support Emergency backup, Sensor



3 Wattage and 5 CCT  
selectable switches



## SURFACE INSTALLATION

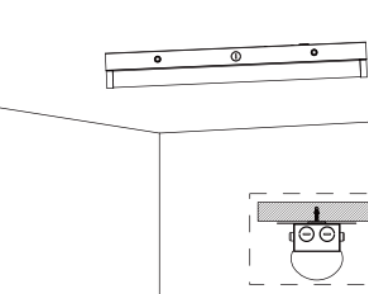

1. Punch a hole on the wall and put the expansion tube inside.

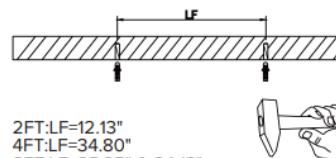

2FT:LF=12.13"  
4FT:LF=34.80"  
8FT:LF=35.35" & 84.13"

2. Turn off the power and wiring by using wire nuts.

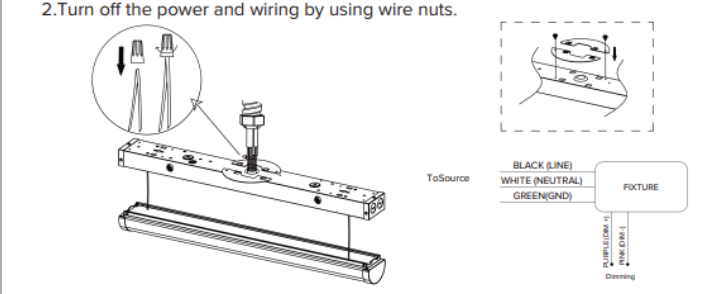

3. Secure the fixture on the wall and lock it in tight.

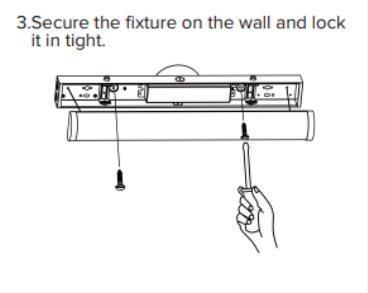

4. Press upward the cover, push side button and press, then lock it with springs tightly which located into the fixture.

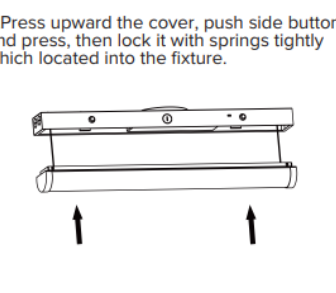

5. The installation completed.

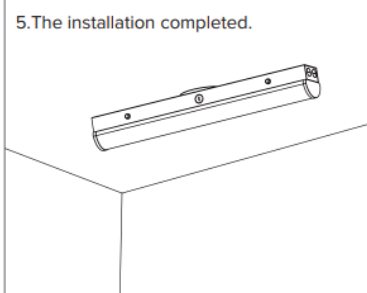

6. Press the buckle on both sides and remove, if you need to disassemble the cover.

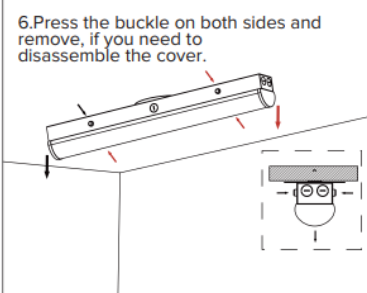

## SUSPENDED INSTALLATION

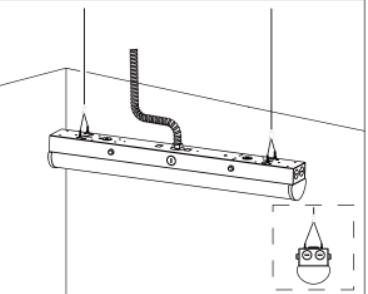

1. Fixing the hook and suspending the lamp.

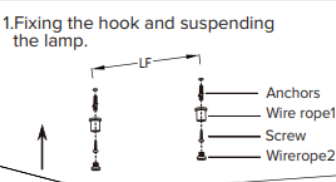

2FT:LF=18.52"  
4FT:LF=41.19"  
8FT:LF=35.59" & 90.50"

2. Adjusting the hanging rope length.

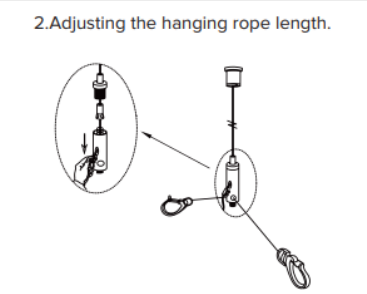

3. Adjusting the hanging rope making the LED Strip in a horizontal state.

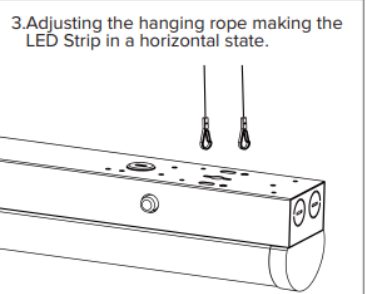

4. Turn off the power and wiring by using wire nuts.

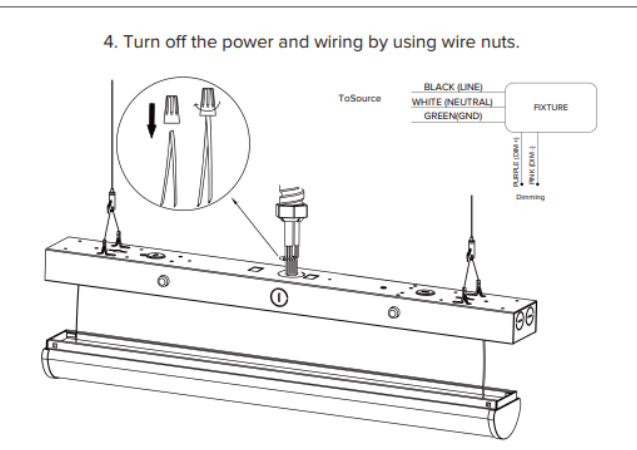



## LINKABLE INSTALLATION

Linkable version available

Each fixtures can achieved seamless connect by the end to end with Daisy Chain(80ft Max)

Connection: Plug the male/female connetor from the previous light to the female/male connector of the next light.

### Caution:

The Linear Strips can be connected  
Max. 450W.

Max. Connection:  
4FT: 10pcs  
8FT: 5pcs

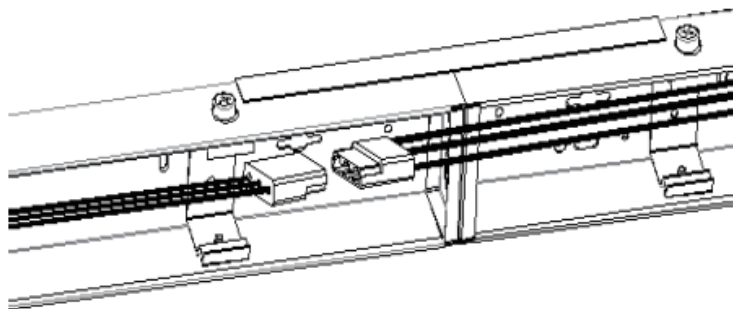

Use a linkable plate (optional) to connect two fixtures on the back.

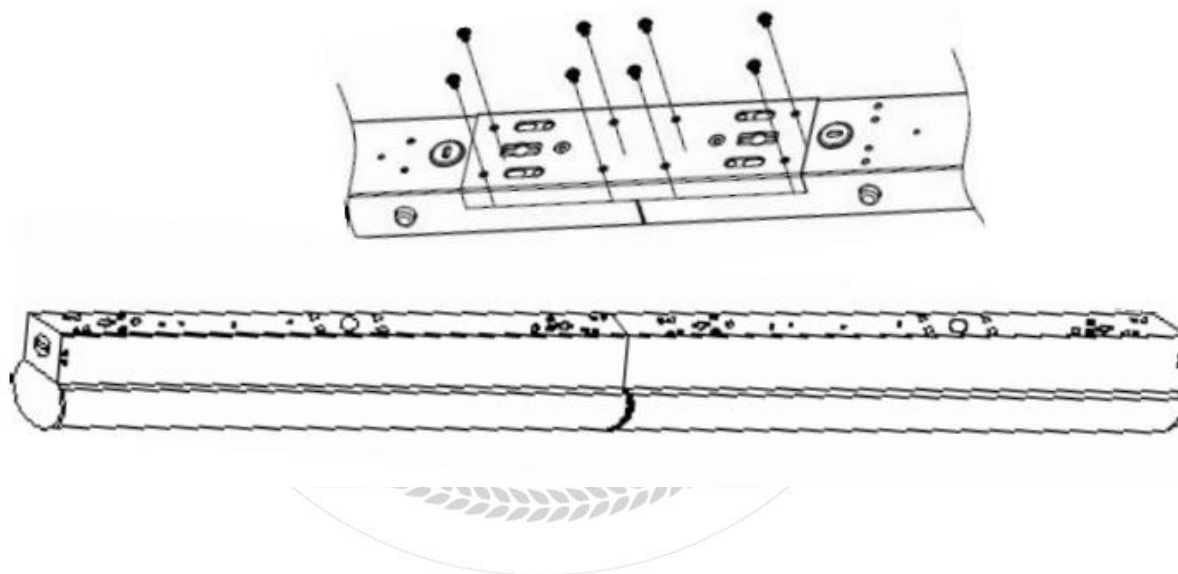

## PRODUCT PACKAGING

Size/ft	L/inch	W/inch	H/inch	PC/Ctn	G.W(lbs)
4ft	50"	10"	7.87"	6PC	27.5lbs
8ft	98"	7.68"	7.87"	4PC	33lbs

\*Tolerance of Carton Size:  $\pm 15$  MM, Tolerance of Weight:  $\pm 10\%$ .



PRODUCT WARNINGS

- ⚡ Please turn off power before install or change assembly parts.
- ⚡ The input voltage and lamps should be matched, after connecting the power line.
- ⚡ Please make sure the wiring section is insulated.
- ⚡ Professionals must install and disassemble the lamps.
- ⚡ Surge is the number 1 cause of LED light failure. Outdoor lights must have surge at fixture, pole, and breaker.
- ⚡ Surge is the number 1 cause of LED light failure. Indoor lights must have surge at fixture and breaker.

PRODUCT TROUBLESHOOTING

Issue	Check points
Light Flickers	Check all wiring for disconnections, shorts and burnt wiring and connections. Confirm steady input voltage to the light fixture, fluctuating input voltage will harm the LED driver and can lead to premature failure. Lights with photocells can have photocell tag from ambient light or light reflecting at the sensor. Simply cover the photocell completely and see if flickering continues while the photocell is covered. Call Tech Support for help if none of the above solves the issue.
Light does not work at all.	Check all wiring for disconnections, shorts and burnt wiring and connections. Confirm steady input voltage to the light fixture, fluctuating input voltage will harm the LED driver and can lead to premature failure. If input voltage is not in the voltage range of the fixture, you will need to find the source of your input voltage issue. Call Tech Support for help if none of the above solves the issue.

For more technical information, install questions, troubleshooting help or warranty claims, we have a dedicated US Tech and Customer Support Team to help solve any issues you have and can be reached by email or phone. If you need help with any of our products, we are here for you so that you are never in the dark!

**BETTER LIGHTS.  
BETTER SUPPORT.**

