



SPECIFICATIONS and FEATURES

-  **HIGH VOLTAGE OUTPUT**
170VDC
-  **CONSTANT POWER**
EMERGENCY OUTPUT
-  **Self-Test**



Input Voltage	277-480V AC, 50/60Hz	Output Voltage	400V DC
Input Current	100mA max.	Output Current	200mA max.
Input Power	20W max.	Output Power	30W/40W/60W
Emergency Time	90 minutes	Battery Type	Lithium ion
Charging Time	≥24 hours	Ambient Temp	0°C ~50°C

For 0-10V dimmable 277-480VAC INPUT LED fixtures, such as LED UFO highbay, linear highbay...



PRODUCT ADVANTAGES

- Easy Wiring**
Directly connect to AC Input of LED Fixtures. Saves Time and Money on the Jobsite
- CEC Title 20 Compliant**
High efficiency performance meet CA Title 20 battery charge efficiency standards
- Constant Power Performance**
Constant wattage delivery maintains illumination level for the full emergency runtime with no degradation
- Self-Testing**
Monthly and annual self-test features satisfies the periodic testing requirements in accordance with NFPA 101 while the on-board diagnostics provides system readiness with visual indicators.

- UL924 listed for factory and field installation
- Easy wiring: directly connect to AC INPUT OF LED luminaires
- Constant power output
- High Voltage Input : 277-480V AC
- Self testing monthly/yearly
- Meets or exceeds all NEC, IBC, and Life Safety Code Emergency Lighting Requirements
- Suitable for use in dry, damp and wet locations.
- Built-in lithium battery
- RoHS Compliant
- IP65 waterproof



IMPORTANT SAFEGAURDS



IMPORTANT SAFEGAURDS
 When using electrical equipment, basic safety precautions should always be followed including the following
PLEASE READ AND FOLLOW ALL SAFETY INSTRUCTIONS.

- CAUTION:** RISK OF SHOCK-disconnect emergency and normal input power sources before servicing
- ASSEMBLY and FIELD INSTALLATION WIRING: WARNING:** AC power must be off before proceeding with assembly or installation of emergency driver.
- IMPORTANT:** An un-switched AC power source is required(277-480Vac). It is designed for fixtures listed for dry and damp locations
- IMPORTANT:** Customers are advised to charge emergency LED driver 24 hours every 6 months during storage.
- CAUTION:** Make sure all electrical connections conform to the National Electrical Code and all applicable local regulations.
- CAUTION:** This is a sealed unit. Components are not replaceable. Replace the entire LED Emergency Backup unit when necessary.
- CAUTION:** Equipment should be mounted in locations and at heights where it is not be subjected to tampering by unauthorized personnel.
- CAUTION:** The use of accessory equipment is not recommended by the manufacturer and may cause an unsafe condition.
- CAUTION:** Use with grounded, UL Listed, dry or damp location rated fixtures. Case should also be grounded.
- CAUTION:** Battery is rechargeable Li-ion type and must be recycled or disposed of properly
- CAUTION:** Suitable for use in 0°C -50°C ambient temperatures
- CAUTION:** This product is for use in indoor fixtures only. Do NOT use near heated air handling outlets or hazardous locations.. Do not let power supply cords touch hot surfaces. Do not mount near gas or electric heaters. Do not use this equipment for other than its intended use. Failure to follow this may cause an unsafe condition and will void warranty. Servicing of this equipment should be performed by qualified personnel only.

DIMENSIONS

30W/40W : L*W*H=319x77x46.8mm(12.60"x3.03"x1.84"), mounting center 301mm(11.85")
 60W : L*W*H=370x77x46.8mm(14.57"x3.03"x1.84"), mounting center 351mm(13.82")

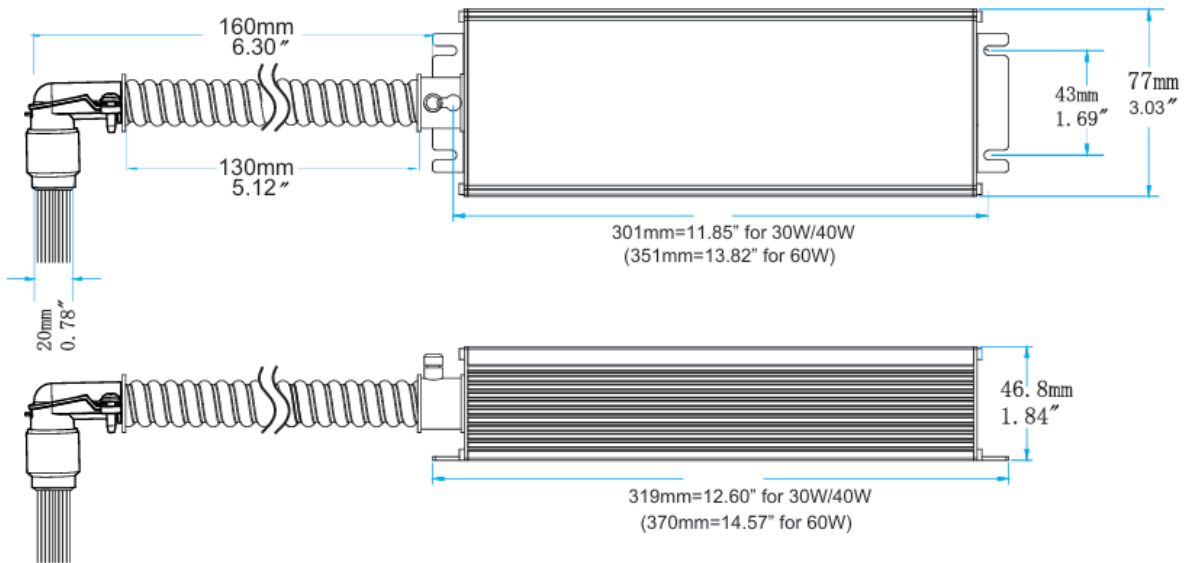

WIRING GUIDE

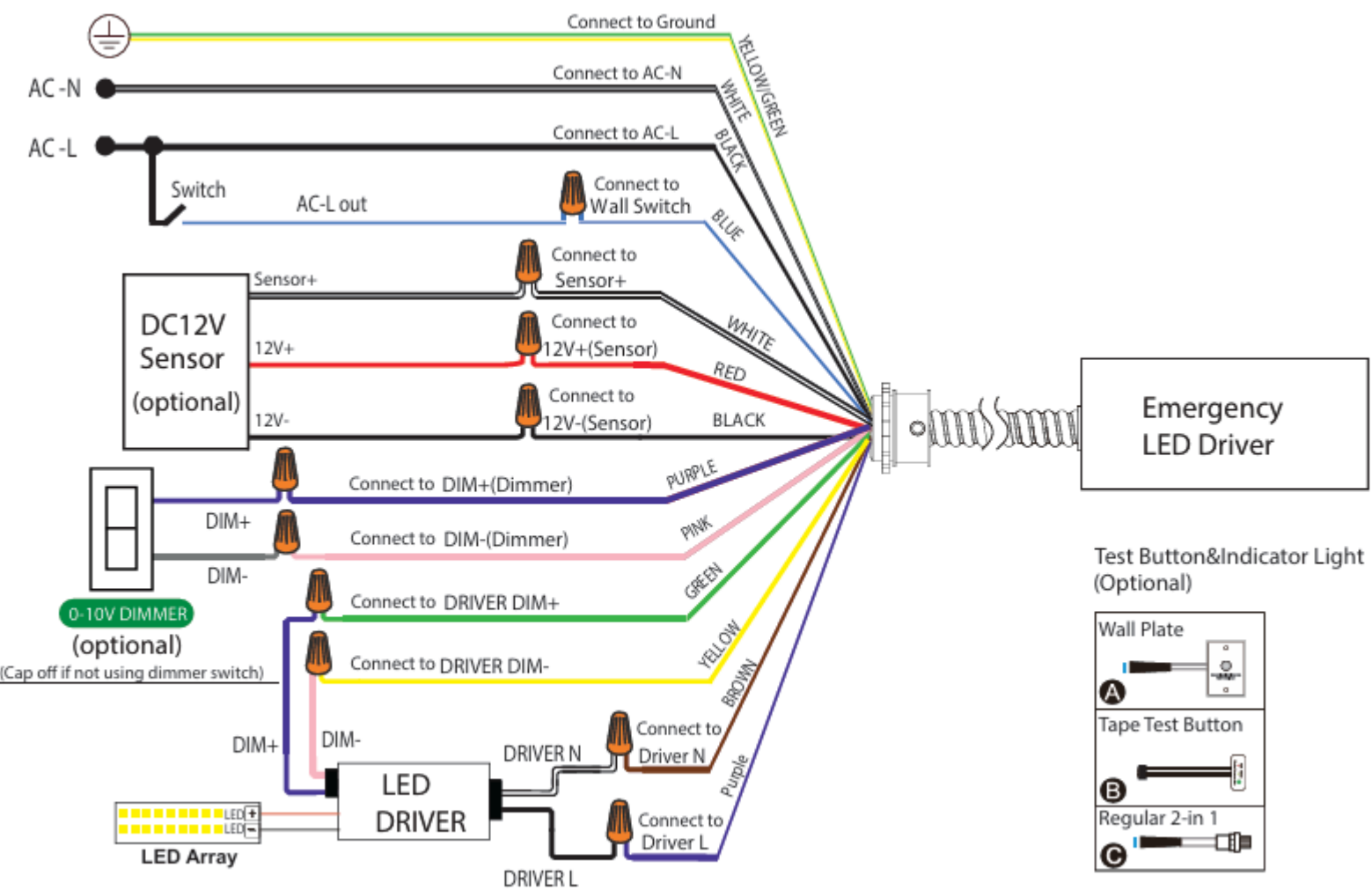

Note: For 277-480VAC 0-10V dimmable LED FIXTURES with an input power less than 300W



OPERATION GUIDE

AC Operation: AC power is present. The AC driver operates the LED load as designed. The emergency driver is charging in a standby mode. The green indicator light flashes shows that the battery is charging. The green indicator light becomes stable shows that the battery is full charged.

Emergency Operation: When the AC power goes out, The emergency driver detects the AC power outage and automatically switch to the working emergency mode. The red indicator light on indicates that it is discharging, the red indicator light flashes to indicate low battery power. The red indicator light off indicates that the discharge is complete. When the AC power is restored, The emergency driver backs to AC power working and starts recharging.

Malfunction Operation:
When the emergency LED driver fault, the yellow indicator light on

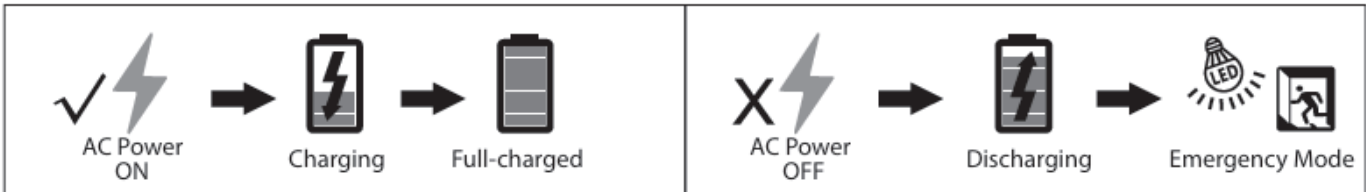

Indicator Light Introduction

- ① Green/Flashing: Charging
- ② Green/ON: Full-charged
- ③ Red/ON: Discharging(emergency mode)
- ④ Red/Flashing: Low battery
- ⑤ Yellow: Error

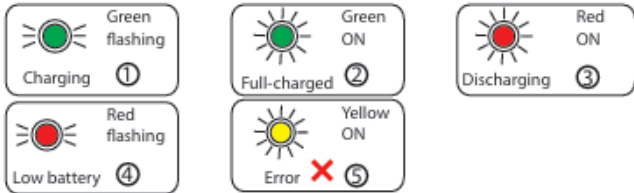

Test Switch Introduction

- ① Press the test switch to confirm whether emergency function is normal
- ② During Emergency Mode, Press test switch twice to cut off the emergency output and enter Shipping Mode

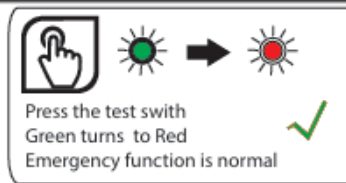

Direct Wiring
277~480V AC
30W/40W/60W

 277-480Vac

