



2835R Series

Standard 2835 package to address retrofit applications

2835R Series is a complementary portfolio with optimized performance and bin construction for the retrofit space. With an industry standard footprint, it provides the perfect balance between performance and cost efficiency for a variety of applications.



FEATURES AND BENEFITS

Flexible voltage configurations to comply with various different system solutions

Industry standard footprint for drop-in replacement designs

High maximum drive current to allow for reduction of LED count

PRIMARY APPLICATIONS

Downlights

High Bay and Low Bay

Outdoor Area Lighting

Lamps

Table of Contents

General Product Information	2
Product Test Conditions	2
Part Number Nomenclature	2
Lumen Maintenance	2
Environmental Compliance	2
Performance Characteristics	3
Product Selection Guide	3
Optical Characteristics	6
Electrical and Thermal Characteristics	7
Absolute Maximum Ratings	7
Characteristics Curves	8
Light Output Characteristics	8
Forward Current Characteristics	11
Radiation Pattern Characteristics	14
Product Bin and Labeling Definitions	15
Decoding Product Bin Labeling	15
Luminous Flux Bins	16
Luminous Efficacy Bins	17
Color Bin Definition	18
Forward Voltage Bins	27
Mechanical Dimensions	28
Reflow Soldering Guidelines	30
JEDEC Moisture Sensitivity	30
Solder Pad Design	31
Packaging Information	33
Pocket Tape Dimensions	33
Reel Dimensions	33

General Product Information

Product Test Conditions

The 2835R Series LEDs are tested and binned with a 20ms monopulse of rated current at a junction temperature, T_j , of 25°C.

Part Number Nomenclature

Part numbers for the 2835R Series follow the convention below:

L 1 2 8 – **A A B B R C 3 5 0 0 D D D**

Where:

- A A** – designates nominal CCT (27=2700K, 30=3000K, 35=3500K, 40=4000K, 50=5000K, 57=5700K, 65=6500K)
- B B** – designates nominal CRI (70=70CRI, 75=75CRI, 80=80CRI and 90=90CRI)
- C** – designates voltage (A=3V, B=6V, C=9V, D=18V, E=36V)
- D D D** – designates Lumileds internal code (0A1, 0B1, 0C1, 0D1, 0E1, etc.=shares the same base part)

Therefore, the following part number is used for a 2835R 3000K, 80CRI, 36V LED:

L 1 2 8 – **3 0 8 0 R E 3 5 0 0 0 A 1**

Lumen Maintenance

Please contact your local Sales Representative or Lumileds Technical Solutions Manager for more information about the long-term performance of this product.

Environmental Compliance

Lumileds LLC is committed to providing environmentally friendly products to the solid-state lighting market. The 2835R Series is compliant to the European Union directives on the restriction of hazardous substances in electronic equipment, namely the RoHS Directive 2011/65/EU and REACH Regulation (EC) 1907/2006. Lumileds LLC will not intentionally add the following restricted materials to its products: lead, mercury, cadmium, hexavalent chromium, polybrominated biphenyls (PBB) or polybrominated diphenyl ethers (PBDE).

Performance Characteristics

Product Selection Guide

Table 1a. Product flux performance of 2835R Series at rated current, T_j=25°C.

PRODUCT	NOMINAL CCT	MINIMUM CRI ⁽¹⁾	RATED CURRENT (mA)	LUMINOUS FLUX ⁽¹⁾ (lm)		TYPICAL LUMINOUS EFFICACY (lm/W)	PART NUMBER
				MINIMUM	TYPICAL		
2835R 3V	2700K	80	60	21.0	24.0	129.0	L128-2780RA35000A1
	3000K	80	60	21.5	24.5	131.7	L128-3080RA35000A1
	3500K	80	60	22.0	25.0	134.4	L128-3580RA35000A1
	4000K	80	60	23.0	26.5	142.5	L128-4080RA35000A1
	5000K	80	60	23.0	26.5	142.5	L128-5080RA35000A1
	5700K	80	60	23.0	26.5	142.5	L128-5780RA35000A1
	6500K	80	60	23.0	26.5	142.5	L128-6580RA35000A1
2835R 6V	2700K	80	150	98	111	119	L128-2780RB35000A1
	3000K	80	150	100	114	123	L128-3080RB35000A1
	3500K	80	150	103	117	126	L128-3580RB35000A1
	4000K	80	150	108	123	132	L128-4080RB35000A1
	5000K	80	150	108	123	132	L128-5080RB35000A1
	5700K	80	150	108	123	132	L128-5780RB35000A1
	6500K	80	150	108	123	132	L128-6580RB35000A1
2835R 9V	2700K	75	100	115	129	142	L128-2775RC35000A1
	3000K	75	100	115	130	143	L128-3075RC35000A1
	3500K	75	100	117	133	146	L128-3575RC35000A1
	4000K	75	100	120	136	149	L128-4075RC35000A1
	5000K	75	100	120	136	149	L128-5075RC35000A1
	5700K	75	100	120	136	149	L128-5775RC35000A1
	6500K	75	100	120	136	149	L128-6575RC35000A1
	2700K	80	100	105	120	132	L128-2780RC35000A1
	3000K	80	100	108	123	135	L128-3080RC35000A1
	3500K	80	100	110	126	138	L128-3580RC35000A1
	4000K	80	100	115	132	145	L128-4080RC35000A1
	5000K	80	100	115	132	145	L128-5080RC35000A1
	5700K	80	100	115	132	145	L128-5780RC35000A1
6500K	80	100	115	132	145	L128-6580RC35000A1	

Table 1a continued on next page.

1. Lumileds maintains a tolerance of ±2 on CRI and ±5% on luminous flux measurements.

Table 1a. Product flux performance of 2835R Series at rated current, T_j=25°C (continued).

PRODUCT	NOMINAL CCT	MINIMUM CRI ⁽¹⁾	RATED CURRENT (mA)	LUMINOUS FLUX ⁽¹⁾ (lm)		TYPICAL LUMINOUS EFFICACY (lm/W)	PART NUMBER
				MINIMUM	TYPICAL		
2835R 9V	2700K	80	100	108	123	135	L128-2780RC35000B1
	3000K	80	100	110	125	137	L128-3080RC35000B1
	3500K	80	100	115	129	142	L128-3580RC35000B1
	4000K	80	100	120	135	148	L128-4080RC35000B1
	5000K	80	100	120	135	148	L128-5080RC35000B1
	5700K	80	100	120	135	148	L128-5780RC35000B1
	6500K	80	100	120	135	148	L128-6580RC35000B1
	2700K	90	100	90	102	112	L128-2790RC35000B1
	3000K	90	100	92	104	114	L128-3090RC35000B1
	3500K	90	100	93	105	115	L128-3590RC35000B1
	4000K	90	100	100	113	124	L128-4090RC35000B1
	5000K	90	100	100	113	124	L128-5090RC35000B1
	5700K	90	100	100	113	124	L128-5790RC35000B1
	6500K	90	100	100	113	124	L128-6590RC35000B1
2835R 9V	2700K	75	60	59	67	124	L128-2775RC35000C1
	3000K	75	60	60	67	124	L128-3075RC35000C1
	3500K	75	60	60	69	128	L128-3575RC35000C1
	4000K	75	60	63	71	131	L128-4075RC35000C1
	5000K	75	60	63	71	131	L128-5075RC35000C1
	5700K	75	60	63	71	131	L128-5775RC35000C1
	6500K	75	60	63	71	131	L128-6575RC35000C1
	2700K	80	60	55	62	115	L128-2780RC35000C1
	3000K	80	60	56	64	119	L128-3080RC35000C1
	3500K	80	60	57	66	122	L128-3580RC35000C1
	4000K	80	60	60	70	130	L128-4080RC35000C1
	5000K	80	60	60	70	130	L128-5080RC35000C1
	5700K	80	60	60	70	130	L128-5780RC35000C1
	6500K	80	60	60	70	130	L128-6580RC35000C1
2835R 18V	2700K	70	50	117	133	123	L128-2770RD35000A1
	3000K	70	50	118	134	124	L128-3070RD35000A1
	3500K	70	50	120	137	127	L128-3570RD35000A1
	4000K	70	50	128	145	134	L128-4070RD35000A1
	5000K	70	50	128	145	134	L128-5070RD35000A1
	5700K	70	50	128	145	134	L128-5770RD35000A1
	6500K	70	50	128	145	134	L128-6570RD35000A1
	2700K	80	60	123	140	130	L128-2780RD35000A1
	3000K	80	60	126	143	132	L128-3080RD35000A1
	3500K	80	60	130	146	135	L128-3580RD35000A1
	4000K	80	60	135	155	144	L128-4080RD35000A1
	5000K	80	60	135	155	144	L128-5080RD35000A1
	5700K	80	60	135	155	144	L128-5780RD35000A1
	6500K	80	60	135	155	144	L128-6580RD35000A1

Table 1a continued on next page.

1. Lumileds maintains a tolerance of ±2 on CRI and ±5% on luminous flux measurements.

Table 1a. Product flux performance of 2835R Series at rated current, T_j=25°C (continued).

PRODUCT	NOMINAL CCT	MINIMUM CRI ⁽¹⁾	RATED CURRENT (mA)	LUMINOUS FLUX ⁽¹⁾ (lm)		TYPICAL LUMINOUS EFFICACY (lm/W)	PART NUMBER
				MINIMUM	TYPICAL		
2835R 18V	2700K	70	60	126	143	132	L128-2770RD35000B1
	3000K	70	60	127	145	134	L128-3070RD35000B1
	3500K	70	60	130	147	136	L128-3570RD35000B1
	4000K	70	60	135	152	141	L128-4070RD35000B1
	5000K	70	60	135	152	141	L128-5070RD35000B1
	5700K	70	60	135	152	141	L128-5770RD35000B1
	6500K	70	60	135	152	141	L128-6570RD35000B1
	2700K	80	60	110	126	117	L128-2780RD35000B1
	3000K	80	60	113	129	119	L128-3080RD35000B1
	3500K	80	60	116	132	122	L128-3580RD35000B1
	4000K	80	60	122	139	129	L128-4080RD35000B1
	5000K	80	60	122	139	129	L128-5080RD35000B1
	5700K	80	60	122	139	129	L128-5780RD35000B1
	6500K	80	60	122	139	129	L128-6580RD35000B1
2835R 36V	2700K	80	30	125	140	130	L128-2780RE35000A1
	3000K	80	30	128	143	132	L128-3080RE35000A1
	3500K	80	30	130	146	135	L128-3580RE35000A1
	4000K	80	30	135	155	144	L128-4080RE35000A1
	5000K	80	30	135	155	144	L128-5080RE35000A1
	5700K	80	30	135	155	144	L128-5780RE35000A1
	6500K	80	30	135	155	144	L128-6580RE35000A1

Notes for Table 1a:

1. Lumileds maintains a tolerance of ±2 on CRI and ±5% on luminous flux measurements.

Table 1b. Product efficacy performance of 2835R Series at rated current, $T_j=25^{\circ}\text{C}$ (continued).

PRODUCT	NOMINAL CCT	MINIMUM CRI ^[1]	RATED CURRENT (mA)	LUMINOUS EFFICACY ^[1] (lm)			PART NUMBER
				MINIMUM	TYPICAL	MAXIMUM	
2835R 3V	2700K	80	42	162	171	190	L128-2780RA35000B1
	3000K	80	42	171	181	210	L128-3080RA35000B1
	3500K	80	42	171	181	210	L128-3580RA35000B1
	4000K	80	42	181	190	210	L128-4080RA35000B1
	4500K	80	42	181	190	210	L128-4580RA35000B1
	5000K	80	42	181	190	210	L128-5080RA35000B1
	5700K	80	42	181	190	210	L128-5780RA35000B1
	6500K	80	42	181	190	210	L128-6580RA35000B1
	2700K	80	42	167	176	196	L128-2780RA35000E1
	3000K	80	42	176	186	210	L128-3080RA35000E1
	3500K	80	42	176	186	210	L128-3580RA35000E1
	4000K	80	42	186	196	210	L128-4080RA35000E1
	4500K	80	42	186	196	210	L128-4580RA35000E1
	5000K	80	42	186	196	210	L128-5080RA35000E1
	5700K	80	42	186	196	210	L128-5780RA35000E1
	6500K	80	42	186	196	210	L128-6580RA35000E1
	2700K	80	42	156	164	182	L128-2780RA35000C1
	3000K	80	42	164	173	210	L128-3080RA35000C1
	3500K	80	42	164	173	210	L128-3580RA35000C1
	4000K	80	42	173	182	210	L128-4080RA35000C1
	4500K	80	42	173	182	210	L128-4580RA35000C1
	5000K	80	42	173	182	210	L128-5080RA35000C1
	5700K	80	42	173	182	210	L128-5780RA35000C1
	6500K	80	42	173	182	210	L128-6580RA35000C1
	2700K	80	42	143	151	168	L128-2780RA35000D1
	3000K	80	42	151	159	185	L128-3080RA35000D1
	3500K	80	42	151	159	185	L128-3580RA35000D1
	4000K	80	42	159	168	185	L128-4080RA35000D1
	4500K	80	42	159	168	185	L128-4580RA35000D1
	5000K	80	42	159	168	185	L128-5080RA35000D1
5700K	80	42	159	168	185	L128-5780RA35000D1	
6500K	80	42	159	168	185	L128-6580RA35000D1	

Notes for Table 1b:

1. Lumileds maintains a tolerance of ± 2 on CRI and $\pm 5\%$ on luminous efficacy measurements.

Optical Characteristics

Table 2. Optical characteristics for 2835R Series at rated current, $T_j=25^{\circ}\text{C}$.

PART NUMBER	TYPICAL TOTAL INCLUDED ANGLE ^[1]	TYPICAL VIEWING ANGLE ^[2]
L128-xxxxRx35000x1	160°	120°

Notes for Table 2:

1. Total angle at which 90% of total luminous flux is captured.

2. Viewing angle is the off axis angle from the LED centerline where the luminous intensity is $\frac{1}{2}$ of the peak value.

Electrical and Thermal Characteristics

Table 3. Electrical and thermal characteristics for 2835R Series at rated current, $T_j=25^{\circ}\text{C}$.

PART NUMBER	FORWARD VOLTAGE ⁽¹⁾ (V_f)		
	MINIMUM	TYPICAL	MAXIMUM
L128-xxxxRA35000A1	2.8	3.1	3.3
L128-xxxxRA35000B1	2.6	2.8	3.0
L128-xxxxRA35000C1	2.6	2.8	3.0
L128-xxxxRA35000D1	2.6	2.8	3.0
L128-xxxxRA35000E1	2.6	2.8	3.0
L128-xxxxRB35000A1	5.8	6.2	6.6
L128-xxxxRC35000A1	8.6	9.1	9.6
L128-xxxxRC35000B1	8.6	9.1	9.6
L128-xxxxRC35000C1	8.6	9.0	9.6
L128-xxxxRD35000A1	16.5	18.0	19.5
L128-xxxxRD35000B1	16.5	18.0	19.5
L128-xxxxRE35000A1	34.0	36.0	38.0

Notes for Table 3:

1. Lumileds maintains a tolerance of $\pm 0.05\text{V}$ on forward voltage measurements.

Absolute Maximum Ratings

Table 4. Absolute maximum ratings for 2835R Series.

PARAMETER	MAXIMUM PERFORMANCE
DC Forward Current	80mA for L128-xxxxRA35000A1 150mA for L128-xxxxRA35000B1 150mA for L128-xxxxRA35000C1 80mA for L128-xxxxRA35000D1 150mA for L128-xxxxRA35000E1 150mA for L128-xxxxRB35000A1 100mA for L128-xxxxRC35000A1 100mA for L128-xxxxRC35000B1 60mA for L128-xxxxRC35000C1 60mA for L128-xxxxRD35000A1 60mA for L128-xxxxRD35000B1 30mA for L128-xxxxRE35000A1
ESD Sensitivity (HBM)	1000V
LED Junction Temperature	125°C for
LED Storage Temperature	-40°C to 105°C -35°C to 85°C
Case Temperature	105°C
Reverse Current (25°C, 5V reverse bias)	10µA

Characteristics Curves

Light Output Characteristics

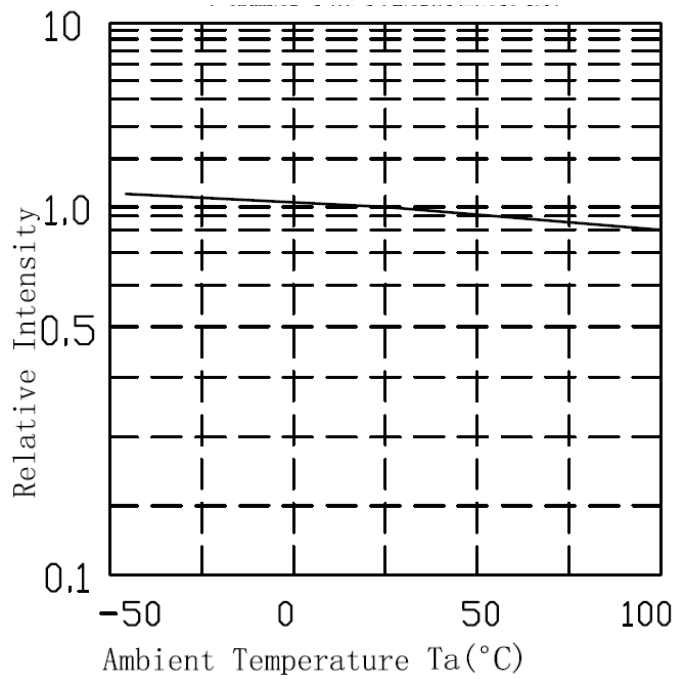

Figure 1. Typical normalized light output vs. ambient temperature for L128-xxxxRx35000x1 at rated current.

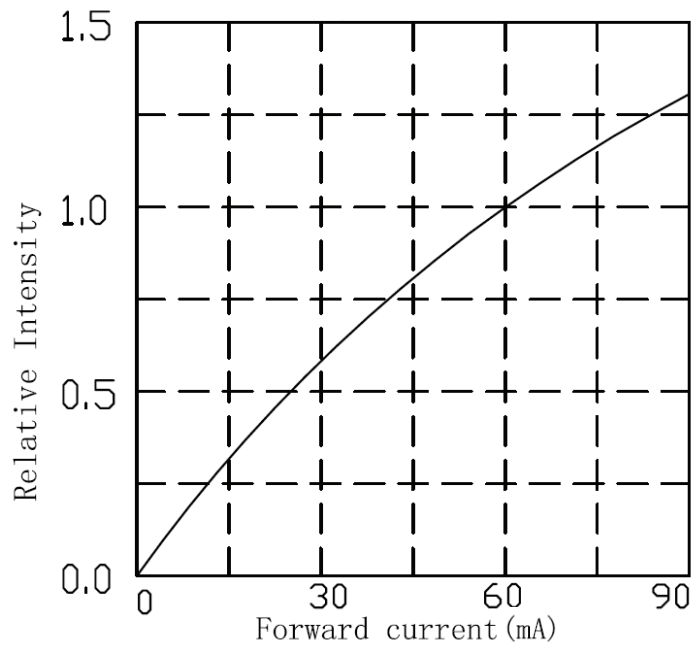

Figure 2a. Typical normalized light output vs. forward current for L128-xxxxRA35000A1 and L128-xxxxRC35000C1 at $T_j=25^\circ\text{C}$.

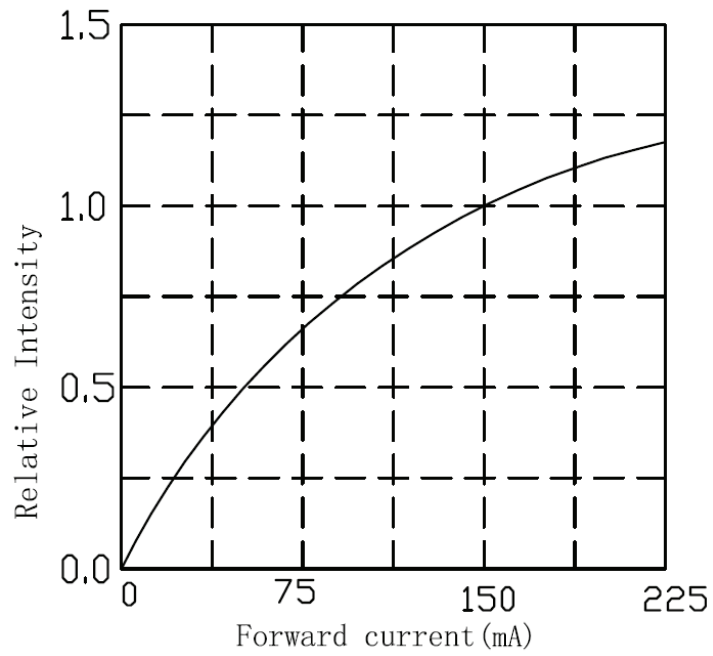

Figure 2b. Typical normalized light output vs. forward current for L128-xxxxRB35000A1 at $T_j=25^\circ\text{C}$.

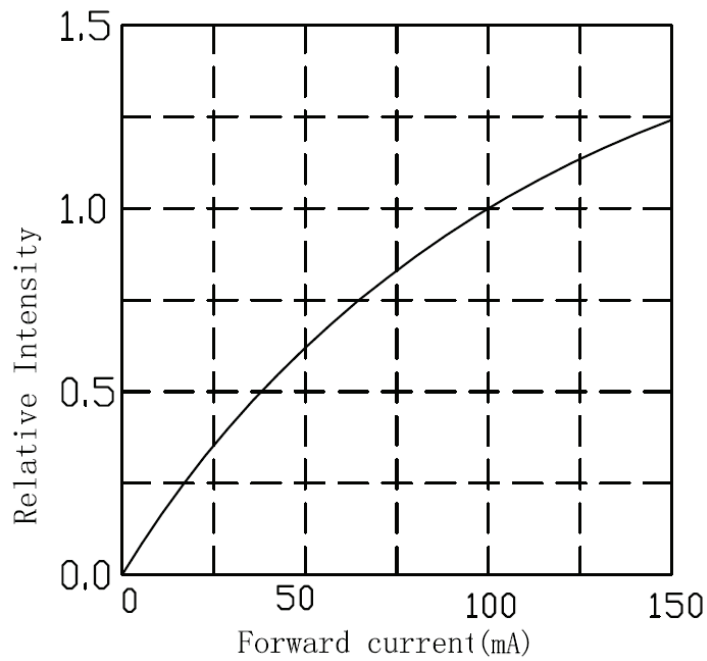

Figure 2c. Typical normalized light output vs. forward current for L128-xxxxRC35000A1 and L128-xxxxRC35000B1 at $T_j=25^\circ\text{C}$.

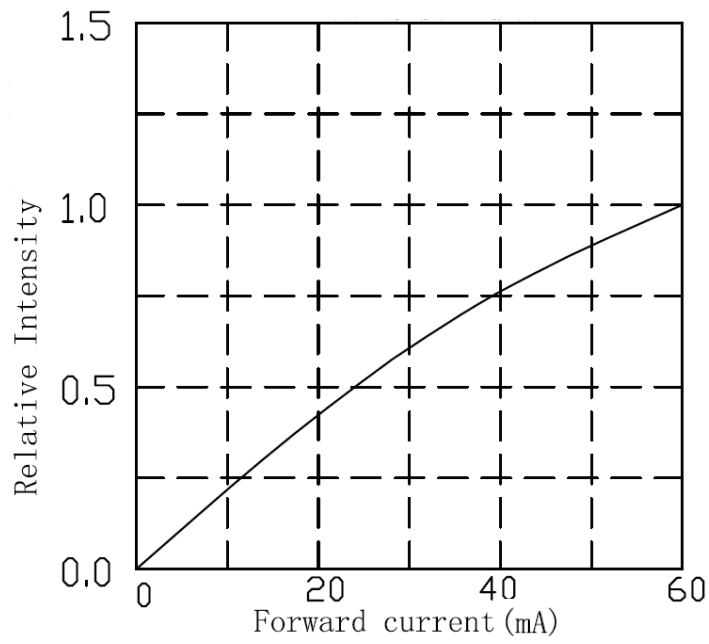

Figure 2d. Typical normalized light output vs. forward current for L128-xxxxRD35000A1 at $T_j=25^\circ\text{C}$.

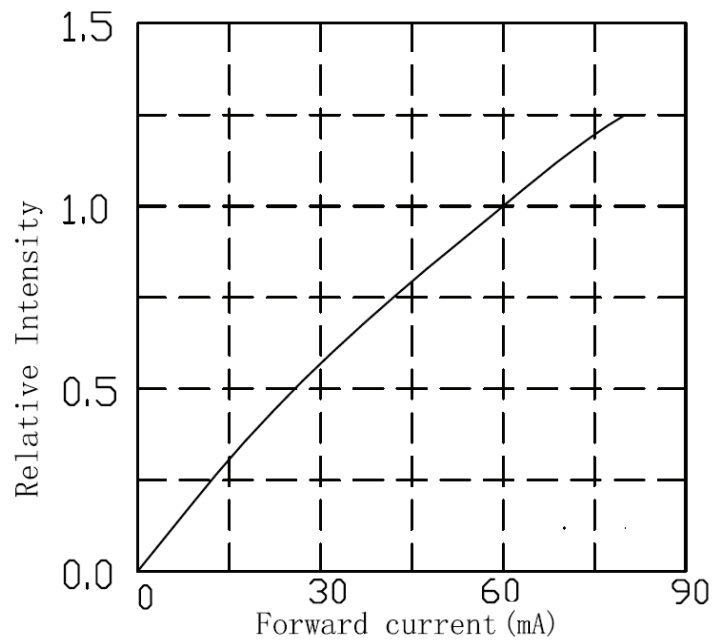

Figure 2e. Typical normalized light output vs. forward current for L128-xxxxRD35000B1 at $T_j=25^\circ\text{C}$.

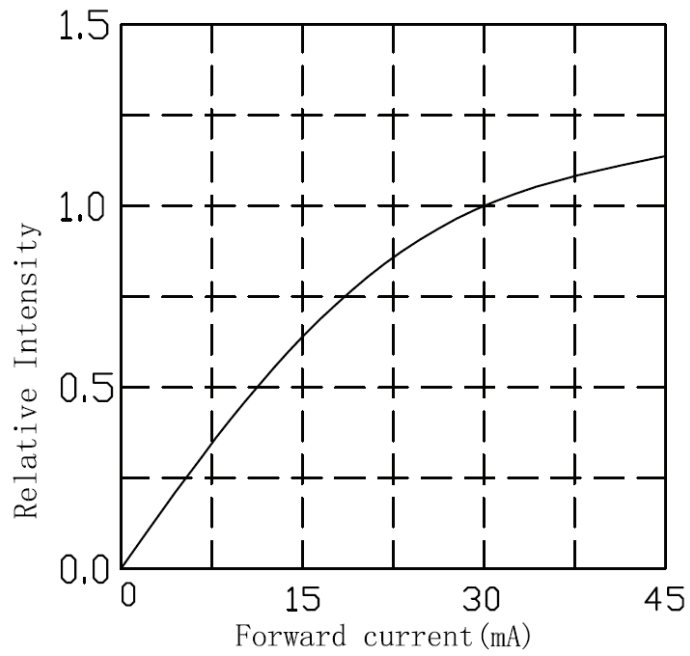

Figure 2f. Typical normalized light output vs. forward current for L128-xxxxRE35000A1 at $T_j=25^\circ\text{C}$.

Forward Current Characteristics

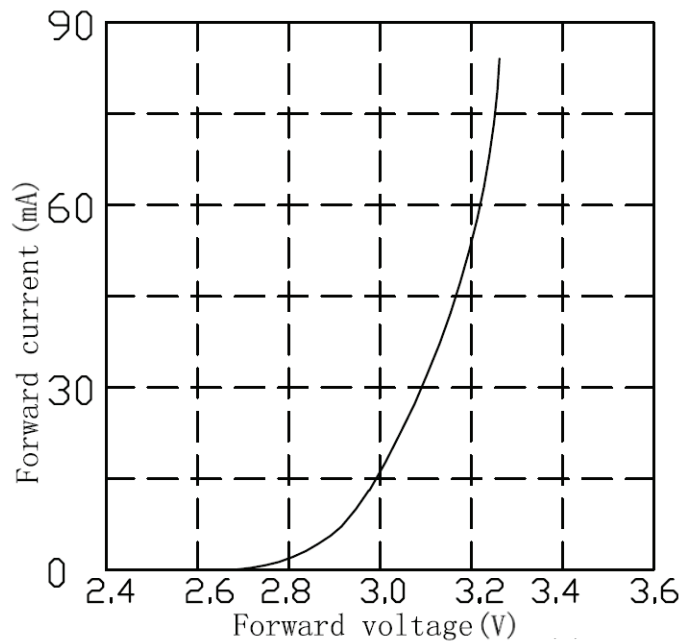

Figure 3a. Typical forward current vs. forward voltage for L128-xxxxRA35000A1 at $T_j=25^\circ\text{C}$.

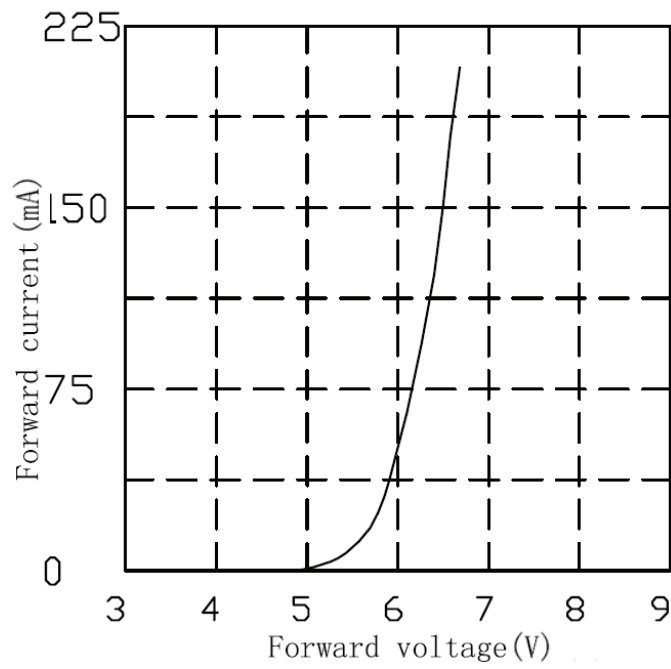

Figure 3b. Typical forward current vs. forward voltage for L128-xxxxRB35000A1 at $T_j=25^\circ\text{C}$.

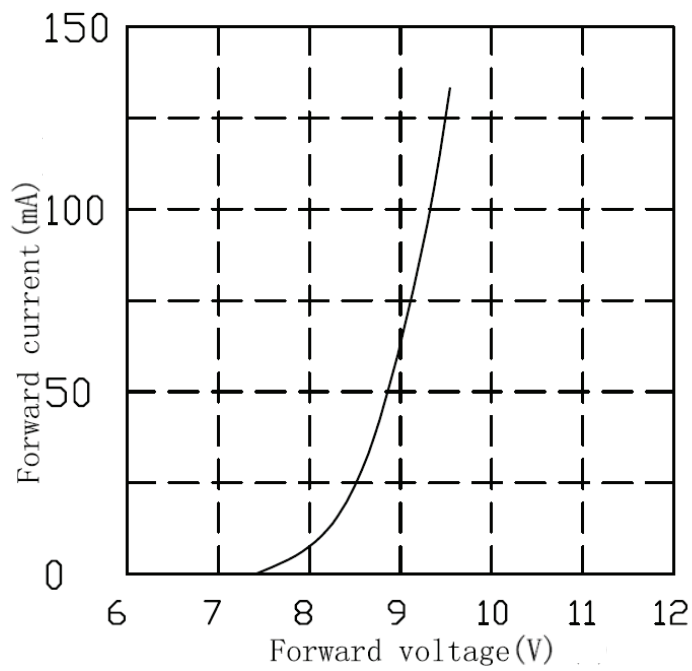

Figure 3c. Typical forward current vs. forward voltage for L128-xxxxRC35000A1 and L128-xxxxRC35000B1 at $T_j=25^\circ\text{C}$.

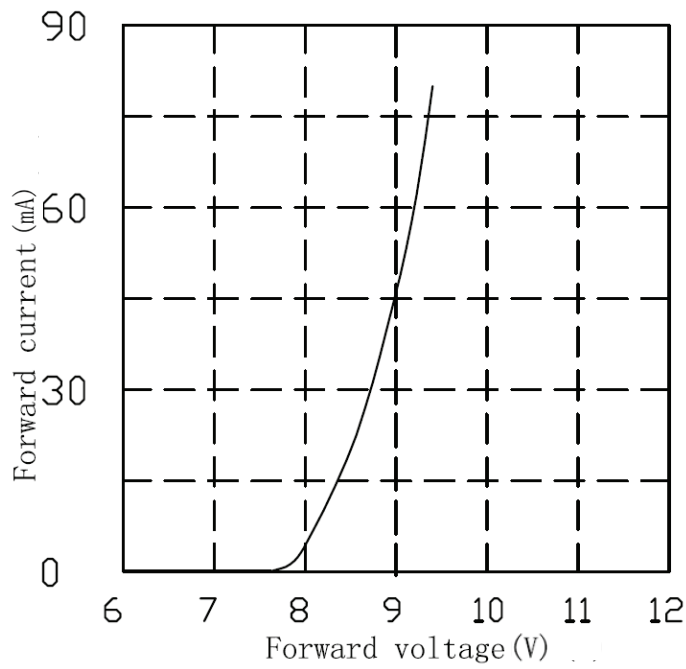

Figure 3d. Typical forward current vs. forward voltage for L128-xxxxRC35000C1 at $T_j=25^\circ\text{C}$.

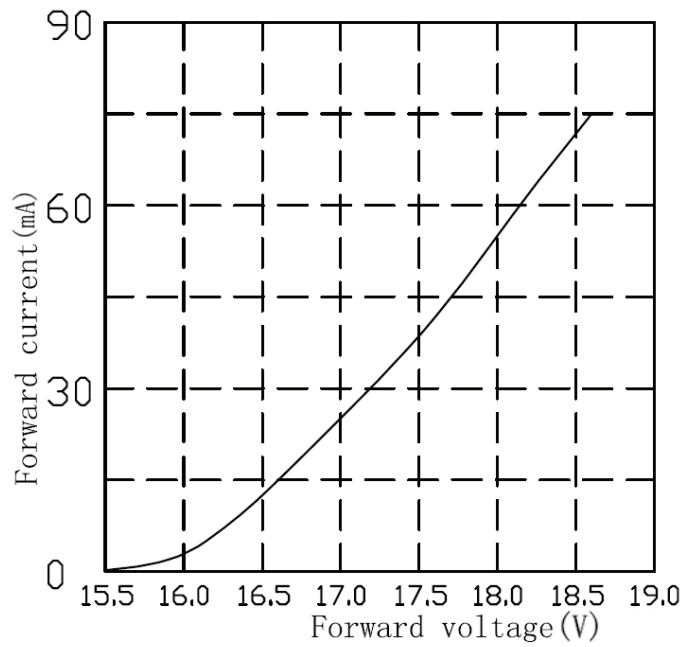

Figure 3e. Typical forward current vs. forward voltage for L128-xxxxRD35000A1 and L128-xxxxRD35000B1 at $T_j=25^\circ\text{C}$.

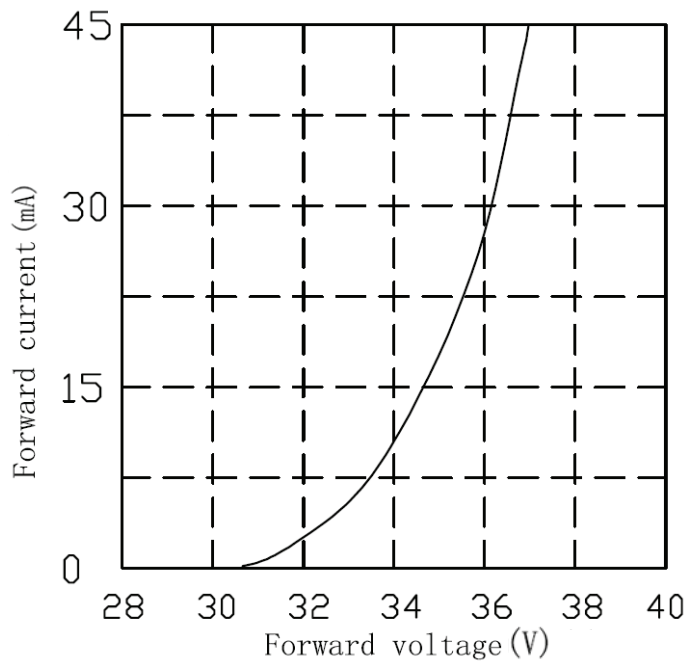

Figure 3f. Typical forward current vs. forward voltage for L128-xxxxRE35000A1 at $T_j=25^\circ\text{C}$.

Radiation Pattern Characteristics

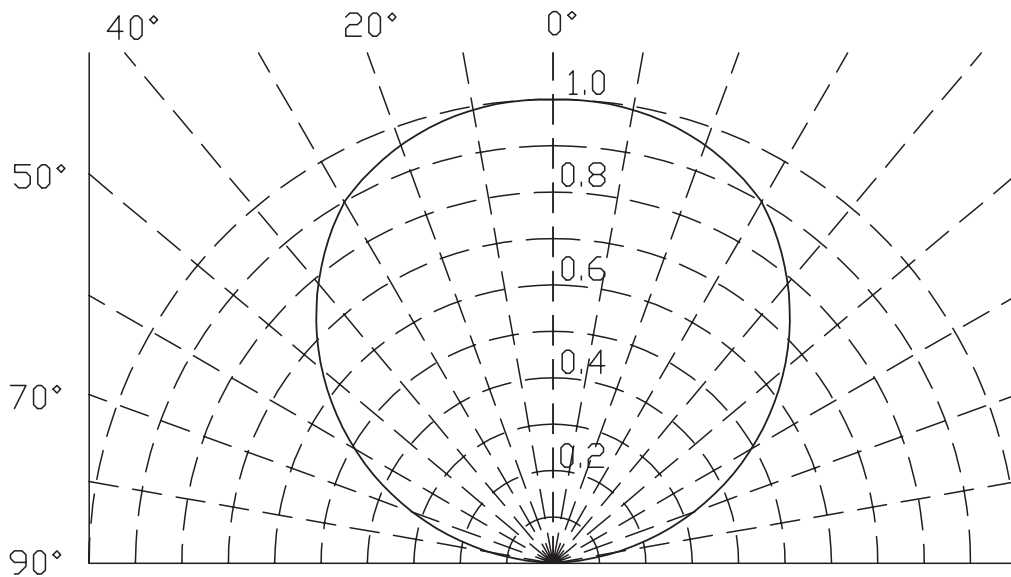

Figure 4. Typical polar radiation pattern for 2835R Series at rated current, $T_j=25^\circ\text{C}$.

Product Bin and Labeling Definitions

Decoding Product Bin Labeling

In the manufacturing of semiconductor products, there are variations in performance around the average values given in the technical datasheet. For this reason, Lumileds bins LED components for luminous flux or luminous efficacy, radiometric power, color point, peak or dominant wavelength, and forward voltage.

2835R Series L128-xxxxRA35000B1, L128-xxxxRA35000C1, L128-xxxxRA35000D1, and L128-xxxxRA35000E1 are labeled using a 5-digit alphanumeric CAT code following the format below:

Where:

A B C D E

- A B** – designates luminous efficacy bin (example: BN=162 to 171 lumens, AK=196 to 210 lumens)
- C D E** – designates correlated color temperature bin (example: 652, 65a, 65b, 65c, 65d, 65e, 65f, 65g, 65h, 65i, 65j for 6500K parts)

Therefore, a 2835R LED with a luminous efficacy range of 162 to 171, color bin of 652 has the following CAT code:

B N 6 5 2

All other 2835R Series LEDs are labeled using a 5-digit alphanumeric CAT code following the format below:

Where:

A B C D E

- A** – designates luminous flux bin (example: B=95 to 100 lumens, G=140 to 150 lumens)
- B C D** – designates correlated color temperature bin (example: A27, A30, A35, A40, A50, A57, A65)
- E** – designates forward voltage bin (example: B=34.5 to 35.0V, H=37.5 to 38.0V)

Therefore, a 2835R 36V LED with a luminous flux range of 95 to 100, color bin of A35 and a forward voltage range of 37.5 to 38.0V has the following CAT code:

B A 3 5 H

Luminous Flux Bins

Table 5 lists the standard luminous flux bins for 2835R Series emitters. Although several bins are outlined, product availability in a particular bin varies by production run and by product performance. Not all bins are available in all CCTs.

Table 5. Luminous flux bin definitions for 2835R Series at rated current, $T_j=25^{\circ}\text{C}$.

PRODUCT	BIN	LUMINOUS FLUX ⁽¹⁾ (lm)	
		MINIMUM	MAXIMUM
L128-xxxxRA35000A1	A	17	19
	B	19	21
	C	21	23
	D	23	25
	E	25	28
	F	28	32
	G	32	36
	H	36	40
	J	40	45
	L128-xxxxRB35000A1 L128-xxxxRC35000A1 L128-xxxxRC35000B1 L128-xxxxRD35000A1 L128-xxxxRD35000B1 L128-xxxxRE35000A1	A	90
B		95	100
C		100	110
D		110	120
E		120	130
F		130	140
G		140	150
H		150	160
J		160	180
L128-xxxxRC35000C1		A	40
	B	45	50
	C	50	55
	D	55	60
	E	60	65
	F	65	70
	G	70	75
	H	75	80

Notes for Table 5:

1. Lumileds maintains a tolerance of $\pm 5\%$ on luminous flux measurements.

Luminous Efficacy Bins

Table 6. Luminous flux bin definitions for 2835R Series at rated current, $T_j=25^{\circ}\text{C}$.

PRODUCT	BIN	LUMINOUS EFFICACY ⁽¹⁾ (lm)	
		MINIMUM	MAXIMUM
L128-xxxxRA35000B1	BN	162	171
	BG	171	181
	BH	181	190
	BK	190	210
L128-xxxxRA35000E1	AL	167	176
	AH	176	186
	AJ	186	196
	AK	196	210
L128-xxxxRA35000C1	BP	156	164
	BQ	164	173
	BR	173	182
	BS	182	210
L128-xxxxRA35000D1	BL	143	151
	BA	151	159
	BB	159	168
	BC	168	185

Notes for Table 6:

1. Lumileds maintains a tolerance of $\pm 5\%$ on luminous efficacy measurements.

Color Bin Definition

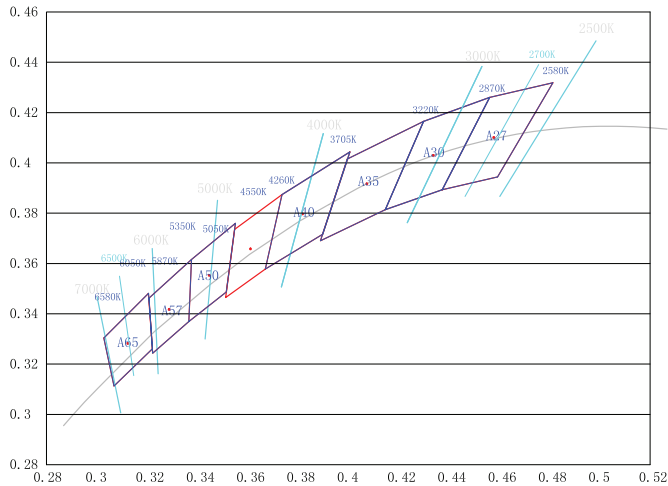

Figure 5a. Color bin structure for 2835R Series for Table 7a.

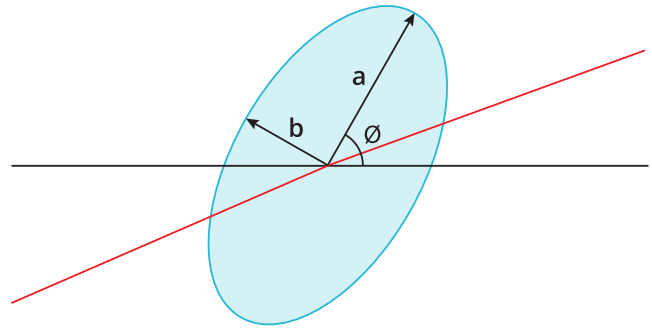

Figure 5b. 3- and 5-step MacAdam ellipse illustration for Tables 7a-7i..

Table 7a. Correlated color temperature bin definitions for 2835R Series at rated current, $T_j=25^\circ\text{C}$

BIN	NOMINAL CCT	POINT	x	y
A27	2700K	1	0.4813	0.4319
		2	0.4562	0.4260
		3	0.4373	0.3893
		4	0.4593	0.3944
A30	3000K	1	0.4562	0.4260
		2	0.4299	0.4165
		3	0.4147	0.3814
		4	0.4373	0.3893
A35	3500K	1	0.4299	0.4165
		2	0.3996	0.4015
		3	0.3889	0.3690
		4	0.4147	0.3814
A40	4000K	1	0.4005	0.4044
		2	0.3736	0.3874
		3	0.3670	0.3578
		4	0.3897	0.3716
A50	5000K	1	0.3551	0.3760
		2	0.3376	0.3616
		3	0.3366	0.3369
		4	0.3515	0.3487
A57	5700K	1	0.3376	0.3616
		2	0.3207	0.3462
		3	0.3222	0.3243
		4	0.3366	0.3369
A65	6500K	1	0.3206	0.3482
		2	0.3028	0.3304
		3	0.3068	0.3113
		4	0.3221	0.3261

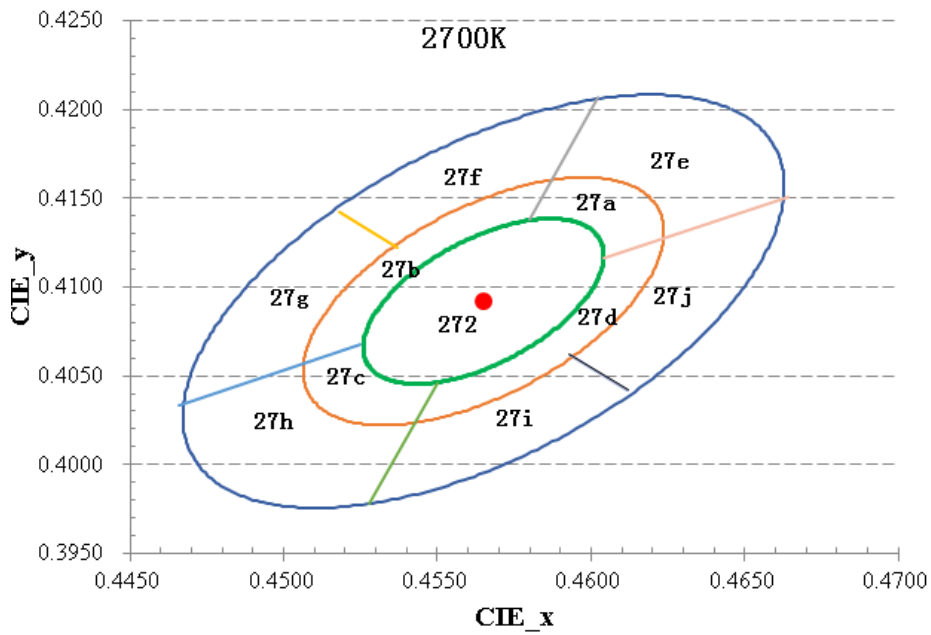

Figure 6a. Color bin structure for 2835R Series 2700K.

Table 7b. Color bin definitions for 2835R Series 2700K, at rated current, $T_j=25^{\circ}\text{C}$.

NOMINAL CCT	POINT	X	y	POINT	X	y
2700K	1	0.4580	0.4138	7	0.4550	0.4046
	2	0.4602	0.4207	8	0.4528	0.3978
	3	0.4537	0.4122	9	0.4593	0.4062
	4	0.4518	0.4142	10	0.4612	0.4042
	5	0.4525	0.4068	11	0.4604	0.4116
	6	0.4466	0.4033	12	0.4664	0.4151
	COLOR SPACE	CENTER Cx	CENTER Cy	MAJOR AXIS, a	MINOR AXIS, b	ELLIPSE ROTATION ANGLE, θ
	Single 2-Step MacAdam ellipse	0.4578	0.4101	0.00540	0.00280	53.70°
	Single 3-Step MacAdam ellipse	0.4578	0.4101	0.00810	0.00420	53.70°
	Single 5-Step MacAdam ellipse	0.4578	0.4101	0.01350	0.00700	53.70°

Notes for Table 7b:

1. Lumileds maintains a tolerance of ± 0.005 on x and y color coordinates in the CIE 1931 color space.

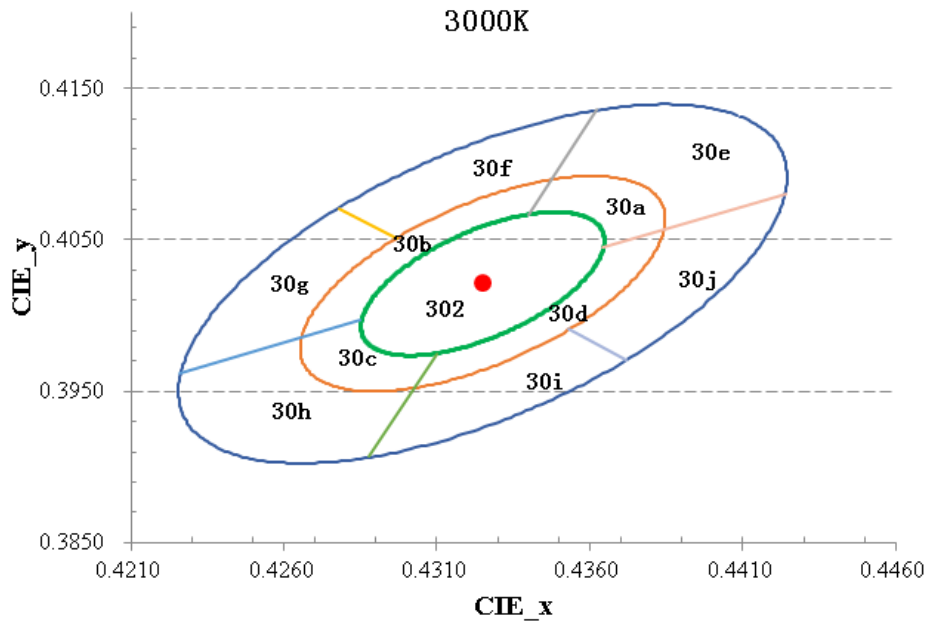

Figure 6b. Color bin structure for 2835R Series 3000K.

Table 7c. Color bin definitions for 2835R Series 3000K, at rated current, $T_j=25^\circ\text{C}$.

NOMINAL CCT	POINT	X	y	POINT	X	y
3000K	1	0.4340	0.4067	7	0.4310	0.3975
	2	0.4362	0.4136	8	0.4288	0.3907
	3	0.4297	0.4051	9	0.4353	0.3991
	4	0.4278	0.4071	10	0.4372	0.3971
	5	0.4285	0.3997	11	0.4364	0.4045
	6	0.4226	0.3962	12	0.4424	0.4080
	COLOR SPACE	CENTER Cx	CENTER Cy	MAJOR AXIS, a	MINOR AXIS, b	ELLIPSE ROTATION ANGLE, θ
	Single 2-Step MacAdam ellipse	0.4338	0.403	0.00556	0.00272	53.22°
	Single 3-Step MacAdam ellipse	0.4338	0.403	0.00834	0.00408	53.22°
	Single 5-Step MacAdam ellipse	0.4338	0.403	0.01390	0.00680	53.22°

Notes for Table 7c:

1. Lumileds maintains a tolerance of ± 0.005 on x and y color coordinates in the CIE 1931 color space.

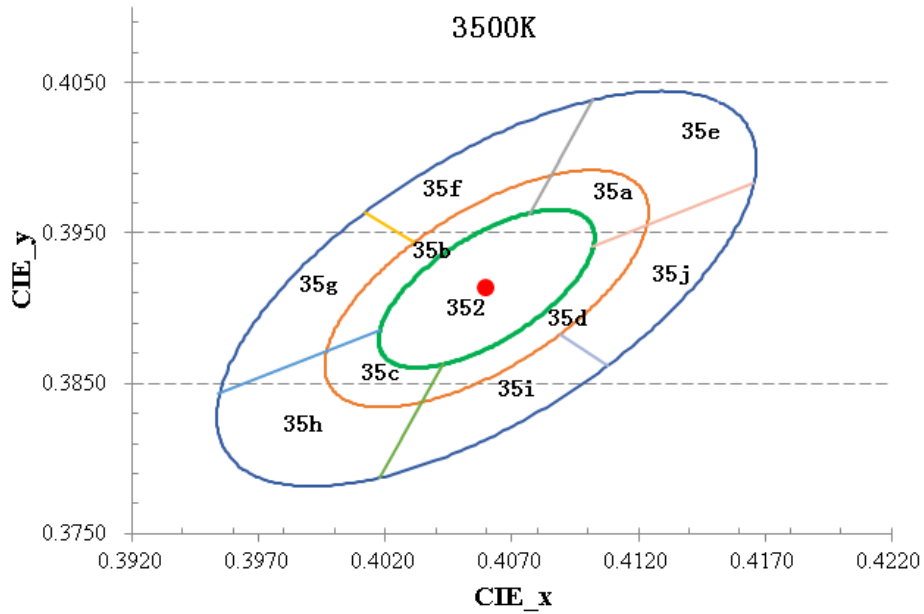

Figure 6c. Color bin structure for 2835R Series 3500K.

Table 7d. Color bin definitions for 2835R Series 3500K, at rated current, $T_j=25^{\circ}\text{C}$.

NOMINAL CCT	POINT	X	y	POINT	X	y
3500K	1	0.4077	0.3963	7	0.4043	0.3863
	2	0.4102	0.4039	8	0.4018	0.3788
	3	0.4031	0.3944	9	0.4089	0.3882
	4	0.4012	0.3964	10	0.4108	0.3862
	5	0.4018	0.3885	11	0.4102	0.3941
	6	0.3954	0.3843	12	0.4165	0.3983
	COLOR SPACE	CENTER Cx	CENTER Cy	MAJOR AXIS, a	MINOR AXIS, b	ELLIPSE ROTATION ANGLE, θ
	Single 2-Step MacAdam ellipse	0.4073	0.3917	0.00618	0.00276	54.00°
	Single 3-Step MacAdam ellipse	0.4073	0.3917	0.00927	0.00414	54.00°
	Single 5-Step MacAdam ellipse	0.4073	0.3917	0.01545	0.00690	54.00°

Notes for Table 7d:

1. Lumileds maintains a tolerance of ± 0.005 on x and y color coordinates in the CIE 1931 color space.

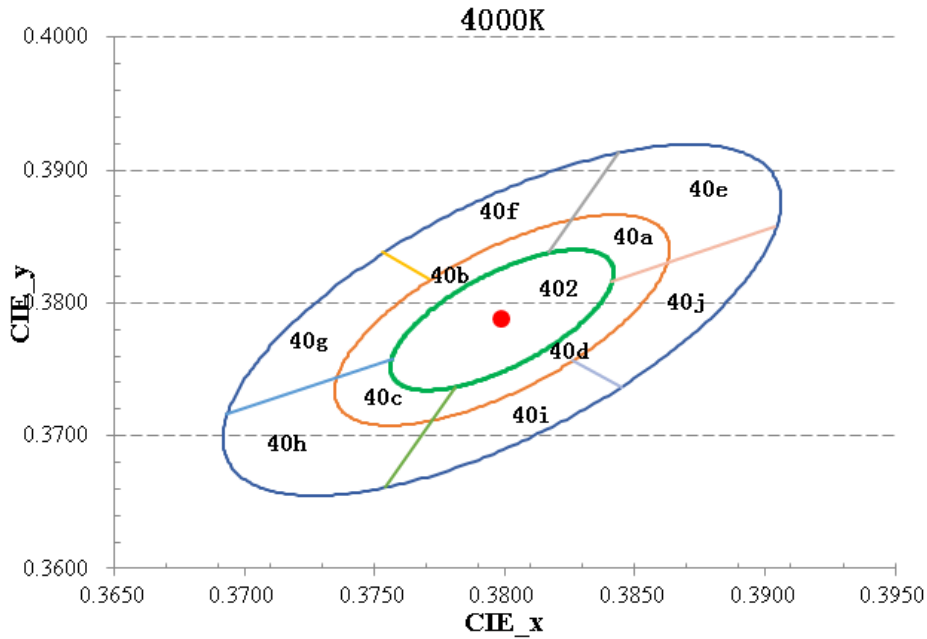

Figure 6d. Color bin structure for 2835R Series 4000K.

Table 7e. Color bin definitions for 2835R Series 4000K, at rated current, $T_j=25^{\circ}\text{C}$.

NOMINAL CCT	POINT	X	y	POINT	X	y
4000K	1	0.3817	0.3838	7	0.3781	0.3737
	2	0.3844	0.3913	8	0.3754	0.3661
	3	0.3771	0.3818	9	0.3826	0.3757
	4	0.3753	0.3838	10	0.3845	0.3737
	5	0.3757	0.3758	11	0.3841	0.3816
	6	0.3693	0.3716	12	0.3904	0.3858
	COLOR SPACE	CENTER Cx	CENTER Cy	MAJOR AXIS, a	MINOR AXIS, b	ELLIPSE ROTATION ANGLE, θ
	Single 2-Step MacAdam ellipse	0.3818	0.3797	0.00626	0.00268	53.72°
	Single 3-Step MacAdam ellipse	0.3818	0.3797	0.00939	0.00402	53.72°
	Single 5-Step MacAdam ellipse	0.3818	0.3797	0.01565	0.00670	53.72°

Notes for Table 7e:

1. Lumileds maintains a tolerance of ± 0.005 on x and y color coordinates in the CIE 1931 color space.

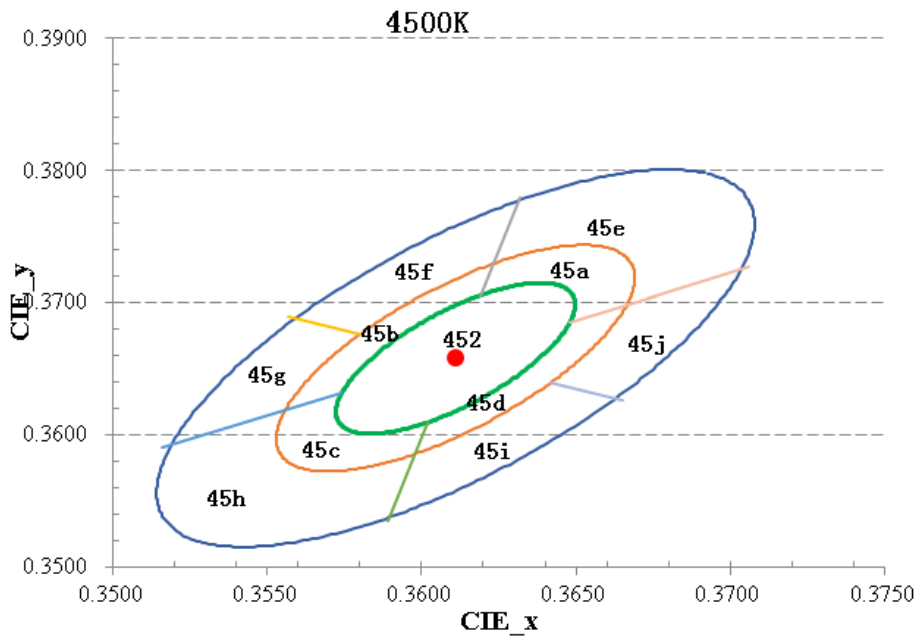

Figure 6e. Color bin structure for 2835R Series 4500K.

Table 7f. Color bin definitions for 2835R Series 4500K, at rated current, $T_j=25^{\circ}\text{C}$.

NOMINAL CCT	POINT	X	y	POINT	X	y
4500K	1	0.3632	0.3780	7	0.3602	0.3609
	2	0.3619	0.3705	8	0.3589	0.3535
	3	0.3557	0.3690	9	0.3665	0.3626
	4	0.3580	0.3676	10	0.3642	0.3640
	5	0.3516	0.3590	11	0.3648	0.3685
	6	0.3574	0.3632	12	0.3706	0.3727
	COLOR SPACE	CENTER Cx	CENTER Cy	MAJOR AXIS, a	MINOR AXIS, b	ELLIPSE ROTATION ANGLE, θ
	Single 2-Step MacAdam ellipse	0.3611	0.3658	0.00240	0.00647	59.62°
	Single 3-Step MacAdam ellipse	0.3611	0.3658	0.00360	0.00971	59.62°
	Single 5-Step MacAdam ellipse	0.3611	0.3658	0.00600	0.01618	59.62°

Notes for Table 7f:

1. Lumileds maintains a tolerance of ± 0.005 on x and y color coordinates in the CIE 1931 color space.

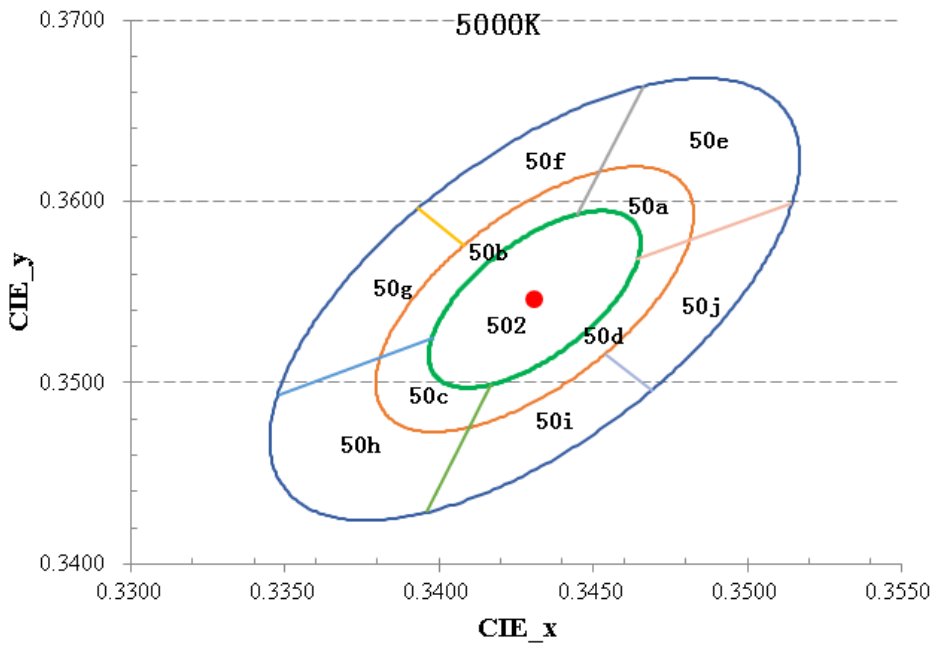

Figure 6f. Color bin structure for 2835R Series 5000K.

Table 7g. Color bin definitions for 2835R Series 5000K, at rated current, $T_j=25^\circ\text{C}$.

NOMINAL CCT	POINT	X	y	POINT	X	y
5000K	1	0.3445	0.3593	7	0.3417	0.3499
	2	0.3466	0.3663	8	0.3396	0.3429
	3	0.3408	0.3576	9	0.3454	0.3516
	4	0.3393	0.3596	10	0.3469	0.3496
	5	0.3398	0.3525	11	0.3464	0.3568
	6	0.3348	0.3493	12	0.3514	0.3599
COLOR SPACE		CENTER Cx	CENTER Cy	MAJOR AXIS, a	MINOR AXIS, b	ELLIPSE ROTATION ANGLE, θ
Single 2-Step MacAdam ellipse		0.3447	0.3553	0.00548	0.00236	59.62°
Single 3-Step MacAdam ellipse		0.3447	0.3553	0.00822	0.00354	59.62°
Single 5-Step MacAdam ellipse		0.3447	0.3553	0.01370	0.00590	59.62°

Notes for Table 7g

1. Lumileds maintains a tolerance of ± 0.005 on x and y color coordinates in the CIE 1931 color space.

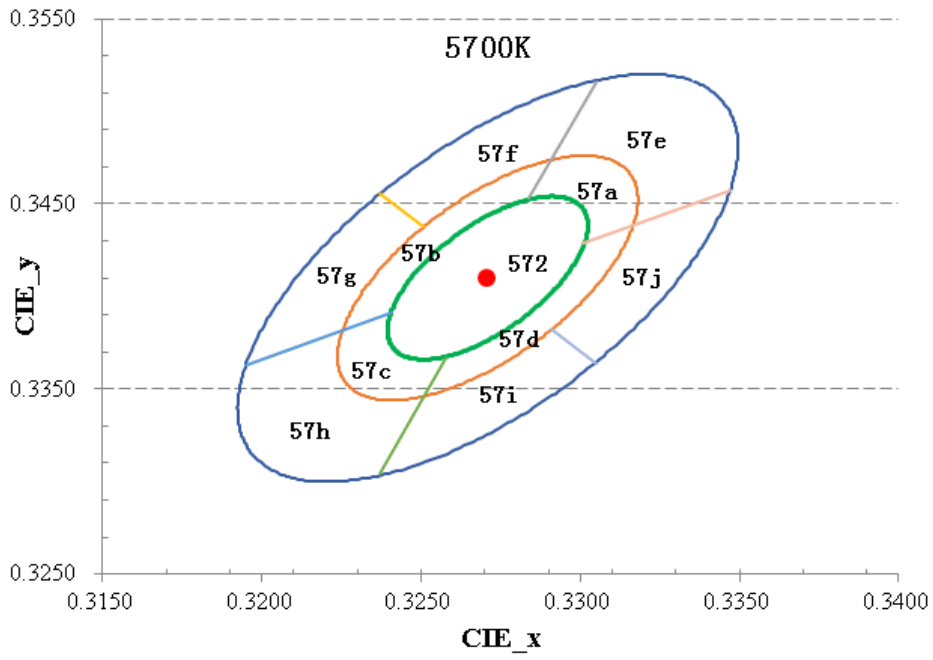

Figure 6g. Color bin structure for 2835R Series 5700K.

Table 7h. Color bin definitions for 2835R Series 5700K, at rated current, $T_j=25^{\circ}\text{C}$.

NOMINAL CCT	POINT	X	y	POINT	X	y
5700K	1	0.3284	0.3453	7	0.3258	0.3367
	2	0.3305	0.3516	8	0.3237	0.3304
	3	0.3251	0.3438	9	0.3305	0.3364
	4	0.3237	0.3456	10	0.3291	0.3382
	5	0.3241	0.3391	11	0.3301	0.3429
	6	0.3195	0.3363	12	0.3347	0.3457
	COLOR SPACE	CENTER Cx	CENTER Cy	MAJOR AXIS, a	MINOR AXIS, b	ELLIPSE ROTATION ANGLE, θ
	Single 2-Step MacAdam ellipse	0.3287	0.3417	0.004973	0.00213	59.09°
	Single 3-Step MacAdam ellipse	0.3287	0.3417	0.007460	0.0032	59.09°
	Single 5-Step MacAdam ellipse	0.3287	0.3417	0.012433	0.00533	59.09°

Notes for Table 7h

1. Lumileds maintains a tolerance of ± 0.005 on x and y color coordinates in the CIE 1931 color space.

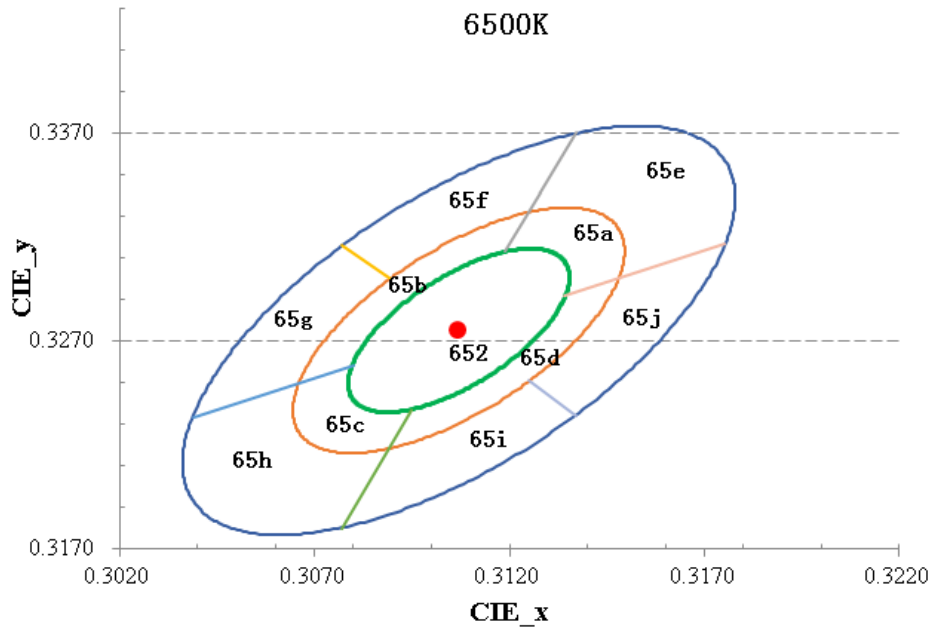

Figure 6h. Color bin structure for 2835R Series 6500K.

Table 7i. Color bin definitions for 2835R Series 6500K, at rated current, $T_j=25^{\circ}\text{C}$.

NOMINAL CCT	POINT	X	y	POINT	X	y
6500K	1	0.3119	0.3313	7	0.3095	0.3237
	2	0.3137	0.3370	8	0.3077	0.3180
	3	0.3089	0.3300	9	0.3125	0.3251
	4	0.3077	0.3316	10	0.3137	0.3234
	5	0.3080	0.3258	11	0.3134	0.3292
	6	0.3039	0.3233	12	0.3175	0.3317
	COLOR SPACE	CENTER Cx	CENTER Cy	MAJOR AXIS, a	MINOR AXIS, b	ELLIPSE ROTATION ANGLE, θ
	Single 2-Step MacAdam ellipse	0.3123	0.3282	0.00446	0.00190	58.57°
	Single 3-Step MacAdam ellipse	0.3123	0.3282	0.00669	0.00285	58.57°
	Single 5-Step MacAdam ellipse	0.3123	0.3282	0.01115	0.00475	58.57°

Notes for Table 7i

1. Lumileds maintains a tolerance of ± 0.005 on x and y color coordinates in the CIE 1931 color space.

Forward Voltage Bins

Table 8. Forward voltage bin definitions for 2835R Series at rated current, $T_j=25^\circ\text{C}$.

PRODUCT	BIN	FORWARD VOLTAGE ⁽¹⁾ (V _f)	
		MINIMUM	MAXIMUM
L128-xxxxRA35000A1	A	2.6	2.7
	B	2.7	2.8
	C	2.8	2.9
	D	2.9	3.0
	E	3.0	3.1
	F	3.1	3.2
	G	3.2	3.3
L128-xxxxRB35000A1	B	5.8	6.0
	C	6.0	6.2
	D	6.2	6.4
	E	6.4	6.6
L128-xxxxRC35000A1 L128-xxxxRC35000B1 L128-xxxxRC35000C1	A	8.6	8.8
	B	8.8	9.0
	C	9.0	9.2
	D	9.2	9.4
	E	9.4	9.6
L128-xxxxRD35000A1 L128-xxxxRD35000B1	B	16.5	17.0
	C	17.0	17.5
	D	17.5	18.0
	E	18.0	18.5
	F	18.5	19.0
	G	19.0	19.5
	L128-xxxxRE35000A1	A	34.0
B		34.5	35.0
C		35.0	35.5
D		35.5	36.0
E		36.0	36.5
F		36.5	37.0
G		37.0	37.5
H		37.5	38.0

Notes for Table 8:

1. Lumileds maintains a tolerance of $\pm 0.05\text{V}$ on forward voltage measurements.

Mechanical Dimensions

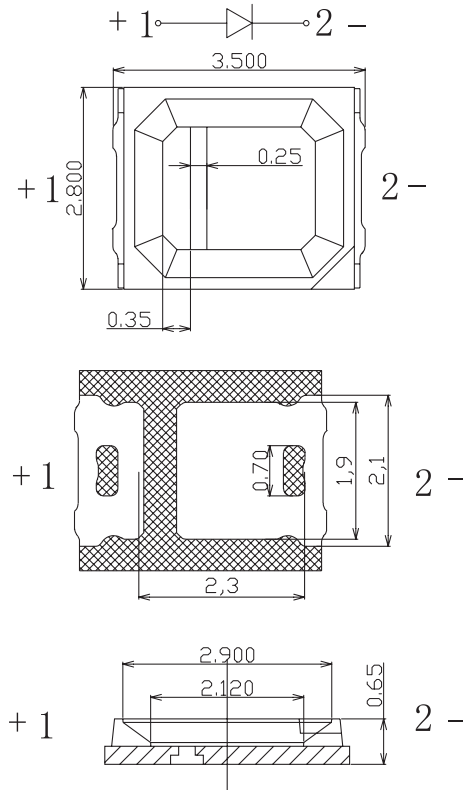

Figure 7a. Mechanical dimensions for L128-xxxxRA35000A1.

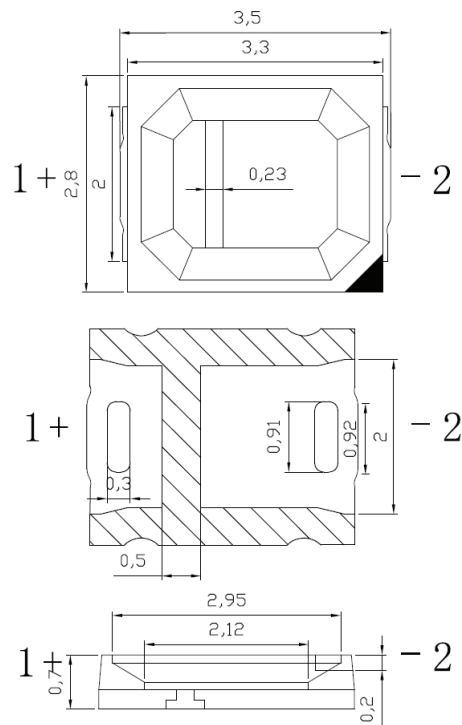

Figure 7b. Mechanical dimensions for L128-xxxxRB35000A1, L128-xxxxRC35000A1, L128-xxxxRC35000B1, L128-xxxxRC35000C1, L128-xxxxRD35000A1, L128-xxxxRD35000B1, and L128-xxxxRE35000A1.

Notes for Figures 7a and 7b:

1. Drawings are not to scale.
2. All dimensions are in millimeters.

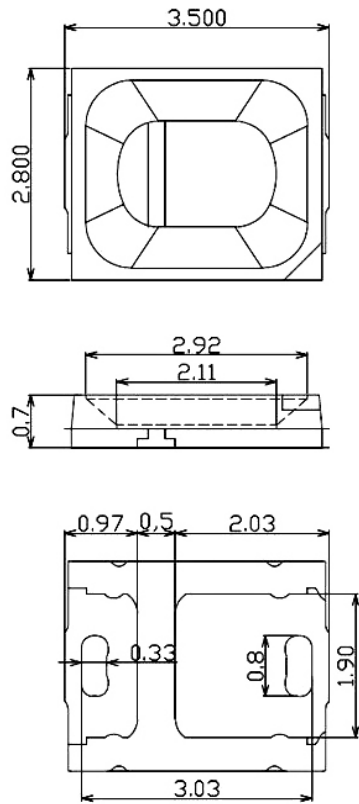

Figure 7c. Mechanical dimensions for L128-xxxxRA35000B1, L128-xxxxRA35000C1, L128-xxxxRA35000D1, and L128-xxxxRA35000E1.

- Notes for Figure 7c:
1. Drawings are not to scale.
 2. All dimensions are in millimeters.

Reflow Soldering Guidelines

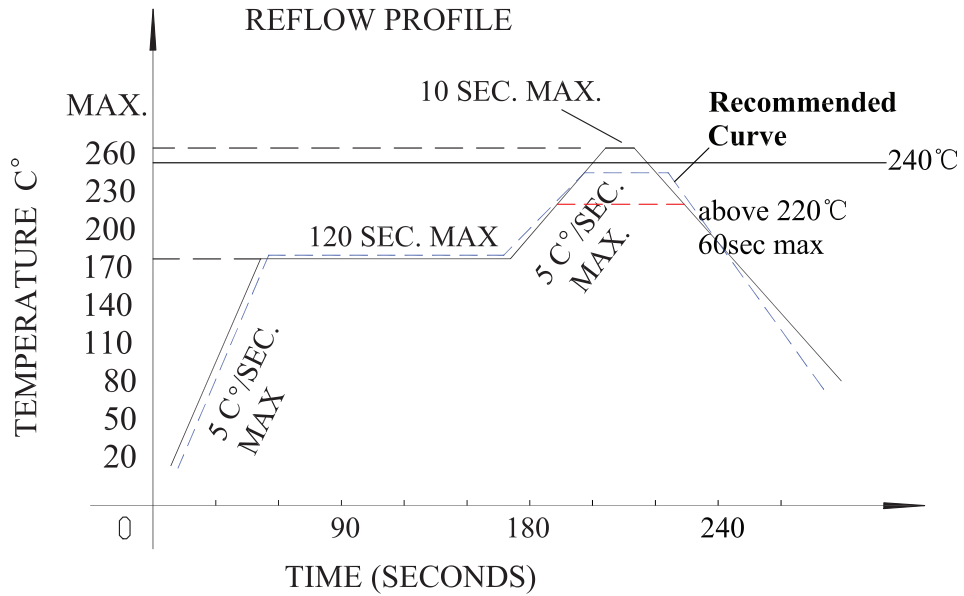

Figure 8. Visualization of the acceptable reflow temperature profile.

Notes for Figure 8:

- 1. Product is highest resistant to 260°C reflow, but suggested the highest temperature of 240°C.

JEDEC Moisture Sensitivity

Table 9. Moisture sensitivity levels for 2835R Series.

LEVEL	FLOOR LIFE		SOAK REQUIREMENTS STANDARD	
	TIME	CONDITIONS	TIME	CONDITIONS
3	72 Hours	≤30°C / 60% RH	96 Hours +2 / -0	30°C / 60% RH

Solder Pad Design

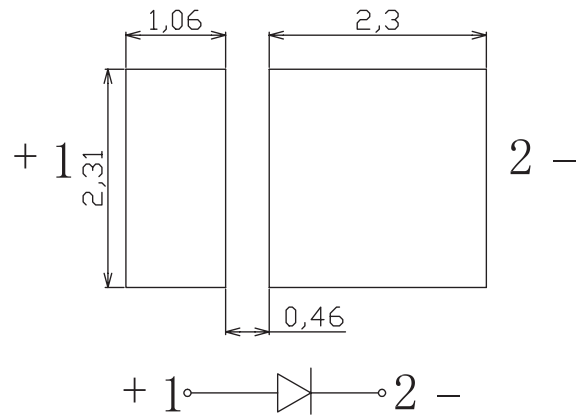

Figure 9a. Recommended PCB solder pad layout for L128-xxxxRA35000A1.

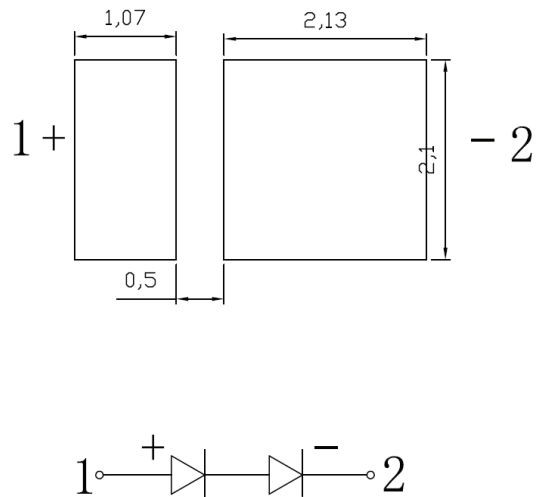

Figure 9b. Recommended PCB solder pad layout for L128-xxxxRB35000A1, L128-xxxxRC35000A1, L128-xxxxRC35000B1, L128-xxxxRC35000C1, L128-xxxxRD35000A1, L128-xxxxRD35000B1, and L128-xxxxRE35000A1..

Notes for Figures 9a and 9b:
 1. Drawings are not to scale.
 2. All dimensions are in millimeters.

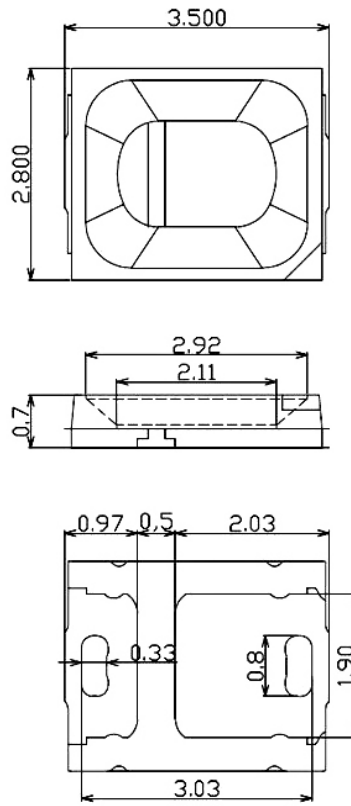

Figure 9c. Recommended PCB solder pad layout for L128-xxxxRA35000B1, L128-xxxxRA35000C1, L128-xxxxRA35000D1, and L128-xxxxRA35000E1.

Notes for Figure 9c:

1. Drawings are not to scale.
2. All dimensions are in millimeters.

Packaging Information

Pocket Tape Dimensions

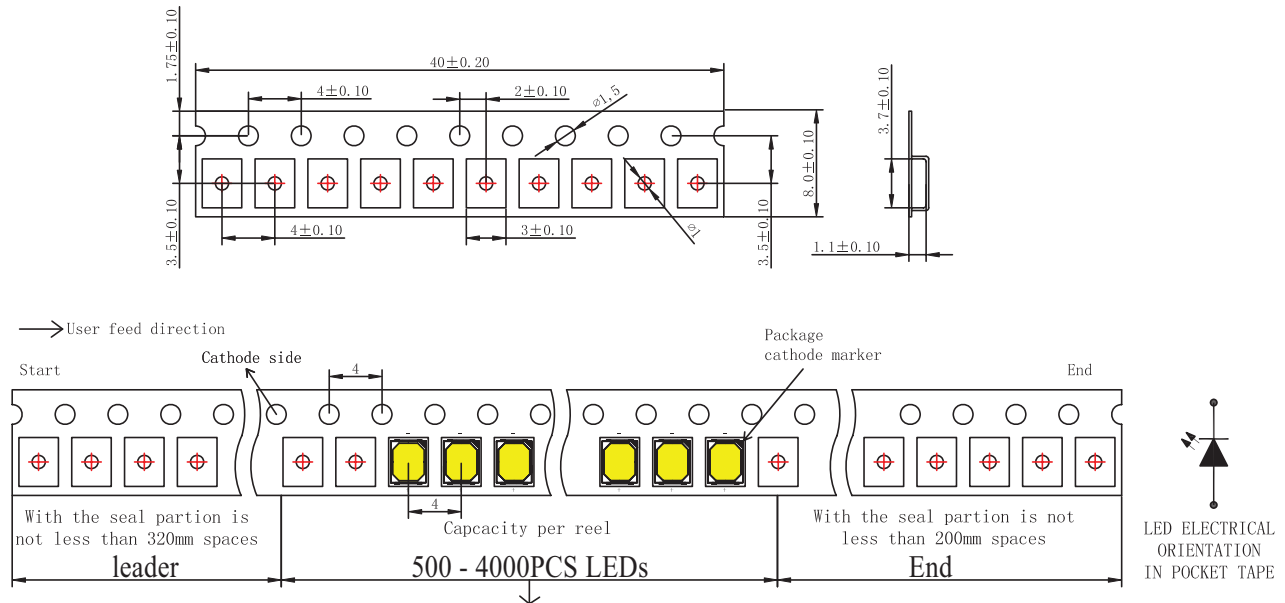

Figure 10. Pocket tape dimensions for 2835R Series.

Notes for Figure 10:

1. Drawings are not to scale.
2. All dimensions are in millimeters.

Reel Dimensions

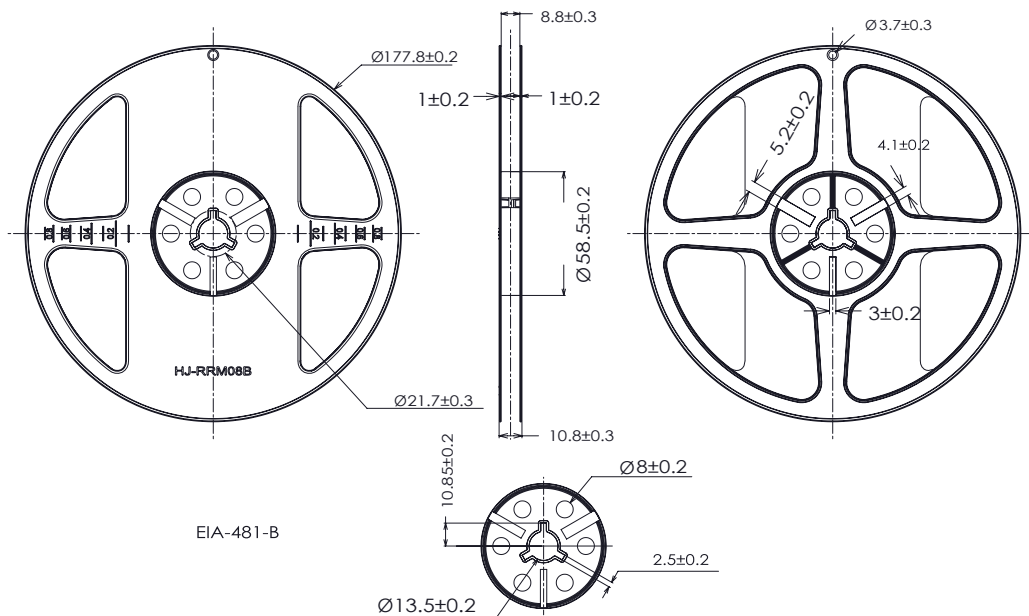

Figure 11. Reel dimensions for 2835R Series.

Notes for Figure 11:

1. Drawings are not to scale.
2. All dimensions are in millimeters.

About Lumileds

Companies developing automotive, mobile, IoT and illumination lighting applications need a partner who can collaborate with them to push the boundaries of light. With over 100 years of inventions and industry firsts, Lumileds is a global lighting solutions company that helps customers around the world deliver differentiated solutions to gain and maintain a competitive edge. As the inventor of Xenon technology, a pioneer in halogen lighting and the leader in high performance LEDs, Lumileds builds innovation, quality and reliability into its technology, products and every customer engagement. Together with its customers, Lumileds is making the world safer, better, more beautiful—with light.

To learn more about our lighting solutions, visit lumileds.com.



©2018 Lumileds Holding B.V. All rights reserved.

lumileds.com

Neither Lumileds Holding B.V. nor its affiliates shall be liable for any kind of loss of data or any other damages, direct, indirect or consequential, resulting from the use of the provided information and data. Although Lumileds Holding B.V. and/or its affiliates have attempted to provide the most accurate information and data, the materials and services information and data are provided "as is," and neither Lumileds Holding B.V. nor its affiliates warrants or guarantees the contents and correctness of the provided information and data. Lumileds Holding B.V. and its affiliates reserve the right to make changes without notice. You as user agree to this disclaimer and user agreement with the download or use of the provided materials, information and data. A listing of Lumileds product/patent coverage may be accessed at lumileds.com/patents.

DS232 2835R Series
Product Datasheet 20180720

Downloaded from Arrow.com