



ELARA SERIES

200W - LED PARKING LOT LIGHT

Product Spec Sheet



COMMERCIAL-GRADE

LED Parking Lot
Light

Product Overview

Elevate your spaces with Elara Series by Hetria Lighting. These cutting-edge LED lights feature integrated drivers, high lumen efficiency, built-in surge protection, UL listing for safety, and a 3-year warranty.

Experience innovation that's smaller, brighter, and environmentally friendly. Illuminate responsibly with Hetria Lighting!

Built to withstand the test of time, our units boast an impressive IP65 waterproof rating and are capable of enduring any harsh weather condition ensuring optimal outdoor performance. Illuminate your world with confidence and reliability.

Product Warranty



3-Year
Limited Warranty



150,000 Hrs

Applications





Factories, Libraries, Parks, Residentials, Supermarkets, Railway Stations, Advertising lighting, etc

Main Features

- **Crystal-Clear White Light:** Drawing just 200W of input power, it delivers an impressive 29,000 lumens. Dimming not available.
- **Elegant & Aesthetic Fixture and Housing:** Design to complement the light, crafted from aluminum with rich, enduring black powder coat for timeless beauty.
- **Flood Mount:** Allows for adjustable positioning on surfaces like walls, poles or ceilings, enabling precise lighting direction.
- **Elegance Meets Performance:** Its stylish design is matched by its impressive functionality so you can install with absolute confidence thanks to its reassuring 3-Year limited warranty.
- **UL Listed:** When you choose UL Certified products you are selecting Superior Quality, Enhance Safety & Unmatched Reliability.
- **Integrated Driver (Driver on Board):** Compact, Sleek & Lightweight! The integrated driver reduces the size, streamlines the design, and lightens the fixture making it more space-efficient for installation with a pleasing appearance.
- **Advanced driver is rated for 120-277VAC exclusively.**
- **Suitable for use in -22°F to 113°F**
- **Eco-friendly:** Printed on recycled material to reduce waste.



Model Specifications

Features	Description
Input Wattage	 200/150/100 Watts (Wattage Selectable)
Kelvin Color	 5000K Bright White Light
LED Chip	 Bridgelux SMD2835(265PCS)
Lumen Performance	 145Lm/Watt. 200W=29000 Lumens
Surge Protection	 6kV Built-in for Extended Lifespan

Key Specifications

- Dimming: 0-10V
- Efficacy: <145lm/W
- Input Voltage & Frequency: 120-277VAC 50/60Hz
- IP: IP65 Waterproof Rating
- Power Factor (PF): >.94
- Total Harmonic Distortion (THD): <20%
- Color Rendering Index (CRI): >80
- Housing & Lens: Die-cast aluminum/ Clear Tempered Glass
- Operating Temperature: -22°F - 113°F

Certifications



Model Specifications

Model	WATT(W)	Lumens (lm)	Efficacy (lm/W)	Mount Type	Kelvin Color (K)	Voltage (V)	CRI
ELARA Series	200W	29,000lm	145lm/W	FM/YM	5000K	120-277VAC	>80

Mounting Options

Flood Mount (FM):

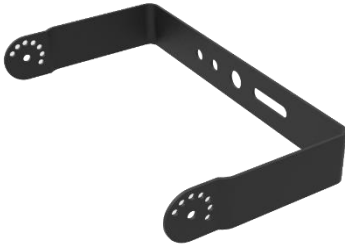

Slip Fit Mount (AM)



Photometric Results – 200W Elara Series Led Parking Lot Light

Luminaire Property

Luminaire Manufacturer:
Voltage: 120.5 V
Power: 200.60 W

Current: 1.672 A
Power Factor: 0.993

Photometric Results

IES Classification: Type III
Total Rated Lamp Lumens: 27917.6 lm
Efficiency: 100%
Upward Ratio: 1%
Central Intensity: 6693.58 cd
Pos of Max. Intensity: H22.5 V68

Longitudinal Classification: Medium
Measurement Flux: 27917.6 lm
Downward Ratio: 99%
Luminaire Efficacy Rating (LER): 139.22
Max. Intensity: 8866.69 cd

Luminous Intensity Distribution Curve

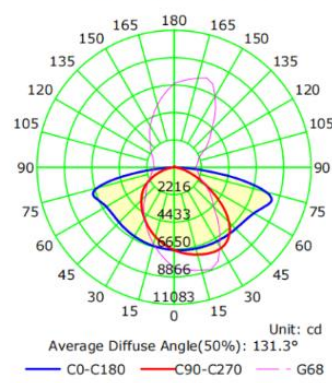

The Average Illuminance Effective Figure

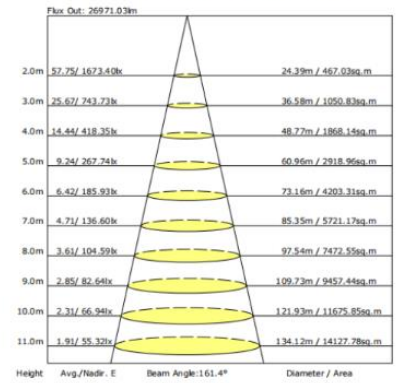

Sizing & Measurem

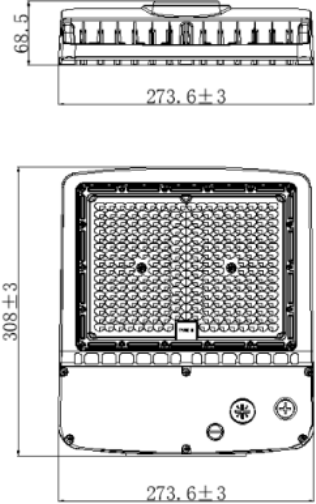
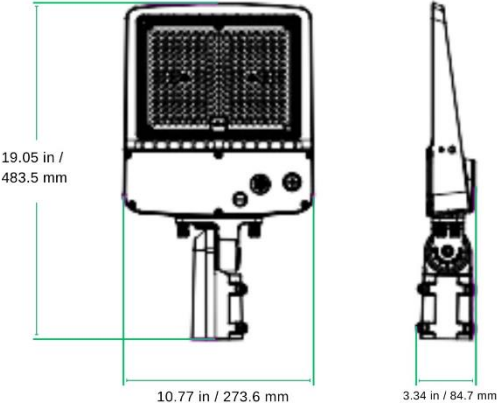
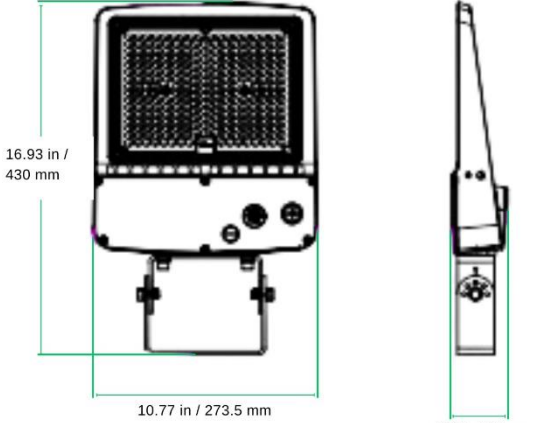
<p>Elara Series FM</p>	<p>7.40</p>	<p>5.98</p>	<p>1.02</p>	
<p>Elara Series AM</p>	<p>19.05</p>	<p>10.77</p>	<p>3.34</p>	 <p style="text-align: center;">AM</p>
<p>Elara Series YM</p>	<p>16.93</p>	<p>10.77</p>	<p>2.70</p>	 <p style="text-align: center;">YM</p>



HL-ELARA-200WBT3A1-abcde50

Manufacturer: RuggedGrade
Brand: Hetria

PRODUCT OVERVIEW

Model Number	HL-ELARA-200WBT3A1-abcde50
Classification	Premium
Primary Use	Outdoor Pole/Arm-Mounted Area and Roadway Luminaires
Reported Input Wattage	199.9 W
Reported Light Output	27575 lm
Reported CCT	5000 K
Reported CRI (Ra)	82
Product ID	S-YL8L3C
DLC Family Code	SLFHHV
Listing Status	Listed
Date Qualified	2025-03-24

PRODUCT INFORMATION

Qualified Product List	Solid State Lighting
Technical Requirements Version	5.1
Product ID	S-YL8L3C
Manufacturer	RuggedGrade
Brand	Hetria
Model Number	HL-ELARA-200WBT3A1-abcde50
Parent	No
Classification	Premium

PRODUCT CATEGORIZATION

[VIEW DETAILS](#)

CONTROL FEATURES

[VIEW DETAILS](#)

REPORTED PHOTOMETRIC PERFORMANCE

Reported Light Output	27575 lm
Reported Efficacy (AC)	137.97 lm/W
Reported CCT	5000 K
Reported CRI (Ra)	82
Reported R9	4
Reported IES Rf	85
Reported IES Rg	95
Reported IES Rcs, h1	-13

REPORTED ELECTRICAL PERFORMANCE

Reported Input Wattage	199.9 W
Reported Total Harmonic Distortion	15 %
Reported Power Factor	0.9
Reported Maximum Input Wattage	199.9
Reported Default Input Wattage	199.9 W
Voltage Range	120-277 V