



The best in sport and area lighting gets better. Icon Pro III has a dual slip-fit and flood bracket mount, individually rotating panels for precise light placement, easily changed lenses for perfect angles, combined with 140+ lumens to watt and DLC 5.1 Certification.

**P/N: RGL-ICONPRO3-500WXYA1-abcd**

Note:

RGL = Rugged Grade Lighting

ICONPRO3 = Product series.

500W = Rating Power

The letter "X" in P/N stands for LED manufactory, B means LUMILEDS 3030

The letter "Y" can be "T1" to "T9", "T1=12°, T2=15°, T3=30°"

The letter "a" can be can be 2 letters represent lamp colors; "BH = Black 、 WH=White 、 BR=Brown or Customized"

The letter "b" can be "C" for Front cover provided or blank for no Front cover provided;

The letter "c" can be "S" or blank to represent Surge protector or None Surge protector;

The letter "d" can be any two-digit number to represent CCT. d=27~65, for2700k~6500k

The letter "e" can be "AM", "DM", "A&D" or "FM" to represent mounting bracket types;



AM



DM



ADM

## Advantage

- UL cUL certificate
- Input voltage 120-277Vac
- No UV or IR in the beam
- Easy to install and operate
- Energy saving, long lifespan
- Instant start, NO flickering, NO humming
- Green and eco-friendly without mercury
- Output constant current lever can be adjusted through output cable with 1-10V.

## Application

- Gymnasium
- Square plaza;
- Shipyard, Airport ,wharf;
- High mast and Contour lighting, etc.

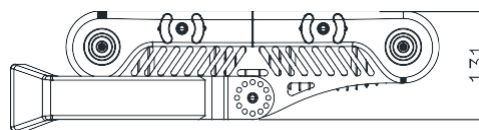
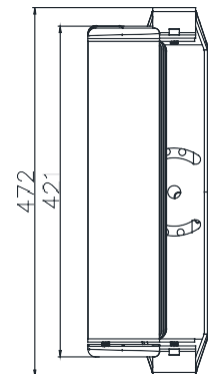
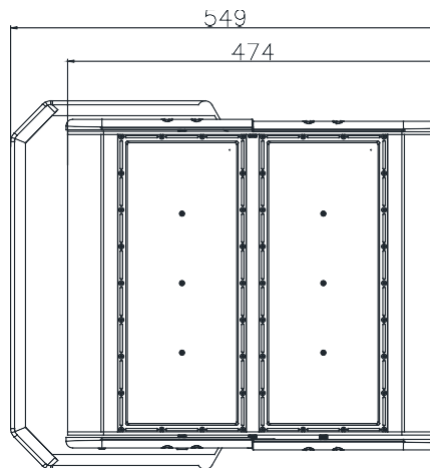

## Specifications

Product name	LED Parking Lot Lights
Part No	RGL-ICONPRO3-500WXYA1-abcd
Dimension	549*421*131 mm

## Technical Characteristic

Color temperature	2700K-5700K
CRI	>70
Lumen	70000-75000LM
Lumen Efficacy	140-150LM/W
Input Power	500W
Beam Angle (50%)	40, 60 and 90 Degree Available
Input Voltage	100-277Vac 50/60Hz
Driver model	SOSEN SS-240VA-56B*2
PF	>0.9
Waterproof Rating	IP65
EPA	2.0ft <sup>2</sup>

## Materials

LED Brand	Seoul
LED Type	3030
LED QTY	576PCS
Housing	Aluminum
Cover	LENS
Housing color	Black / Brown/white/Customized

## Others

Operating Temperature	-40°C TO 50°C
Operating Humidity	10%-90% RH
Storage Temperature	-40°C TO 80°C
Storage Humidity	10%-95%
Application	Outdoor / Indoor
Safety Certification	UL、cUL
Warranty Time	5 Years







## Package

Lamp Net Weight: 17 KG / PC

	Size	Qty / Carton	Gross Weight / Carton
Outer box	549*421*131 mm	1 PC	18.8 KG



## Notice for users

- The input voltage and lamps should be matched, after connecting the power line, Please make sure the wiring section is insulated.
- Do not look directly at the lamp when it is working. It should be used when no one is around.
- In order to ensure the bactericidal effect, please clean up the dust and stains on the luminous surface in time.
- Keep the room clean and dry when disinfecting the air with ultraviolet light. When the indoor temperature is lower than 20°C or the relative humidity is more than 60%, the irradiation time should be extended to ensure the disinfection effect.
- No-professionals, must not install and disassemble the lamps.

## Troubleshooting

Issue	Check points
Light Flickers	Check all wiring for disconnections, shorts and burnt wiring and connections. Confirm steady input voltage to the light fixture, fluctuating input voltage will harm the LED driver and can lead to premature failure. Lights with photocells can have photocell tag from ambient light or light reflecting back at the sensor. Simply cover the photocell completely and see if flickering continues while the photocell is covered. Call Tech Support for help if none of the above solves the issue.
Light does not work at all.	Check all wiring for disconnections, shorts and burnt wiring and connections. Confirm steady input voltage to the light fixture, fluctuating input voltage will harm the LED driver and can lead to premature failure. If input voltage is not in the voltage range of the fixture, you will need to find the source of your input voltage issue. Call Tech Support for help if none of the above solves the issue.

**For more technical information, install questions, troubleshooting help or warranty claims, we have a dedicated US Tech and Customer Support Team to help solve any issues you have and can be reached by email or phone. If you need help with any of our products, we are here for you so that you are never in the dark!**

## BETTER LIGHTS. BETTER SUPPORT.





**CERTIFIED**



**LISTED**



LEGENDARY RUGGEDGRADE QUALITY  
LEGENDARY USA SUPPORT



US based  
phone and online  
customer support



ROCK SOLID  
**5 YEARS**  
WARRANTY

