

500W LED StadiumPro III Stadium Lights | EPA Ratings

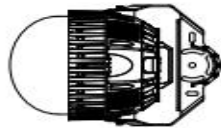

S Single
EPA: 1.0
Weight: 32.7 lbs.

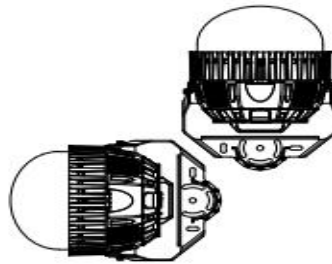

D90 Double 90°
EPA: 2.6
Weight: 65.4 lbs.

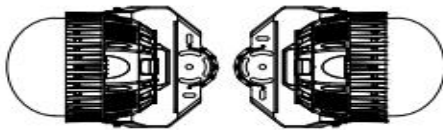

D180 Double 180°
EPA: 2.0
Weight: 65.4 lbs.

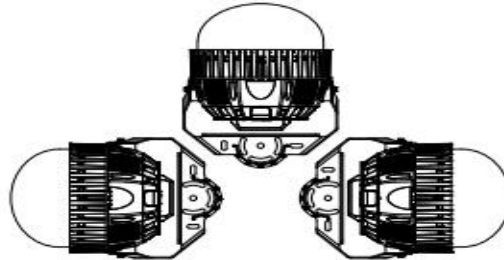

T90 Triple 90°
EPA: 3.6
Weight: 98.1 lbs.

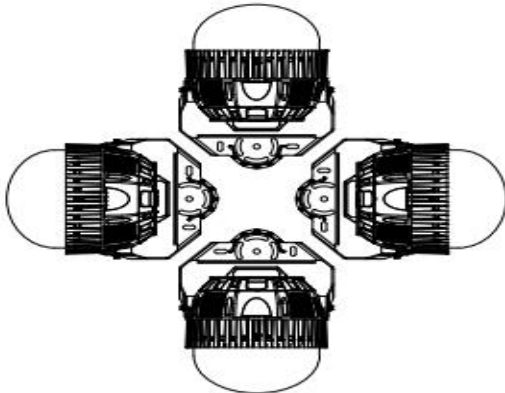

Q90 Quad 90°
EPA: 3.6
Weight: 130.8 lbs.

